

Cole-Parmer®

BM-200 Mixer/Mill

Rock and Mineral Grinder for Spectroscopy Applications

Operation Manual

For 115V/230V (04576-27)



Copyright 2023 by Cole-Parmer

All rights reserved. No part of the work may be reproduced or transmitted in any form or by any means, electronic or mechanical; including photocopying and recording, except as may be expressly permitted by the 1976 Copyright Act or in writing from the publisher.

Requests for permission should be addressed in writing to Cole-Parmer, 65 Liberty Street, Metuchen, NJ 08840.

SPEX SamplePrep is now part of Cole-Parmer®.

The Cole-Parmer® BM-200 Mixer/Mill was formerly known as SPEX 5120 Mixer/Mill.

Over the years, we've acquired many high-quality and reputable brands. After many years of continual growth, we realize our brands are all as brilliant as each other. Rather than have a portfolio of complementary brands, we felt consolidating them under one world-class brand name enabled us to offer a single and significant brand experience. Through one brand we can speak in one voice through our team of experts who provide support in product selection, usage and troubleshooting to empower laboratories to run efficiently throughout the world.

Same Great Quality!

One World-Class Brand Name!

TABLE OF CONTENTS

| SECTION | DESCRIPTION | PAGE |
|---------|--|------|
| 1.0 | Introduction | 4 |
| 2.0 | Specifications | 5 |
| 3.0 | Unpacking | 6 |
| 4.0 | Setting Up | 7 |
| 4.1 | Electrical Connection | 7 |
| 4.2 | Cabinet Set-Up | 7 |
| 4.3 | Standard Safety Features | 7 |
| 4.4 | CE Safety Features | 8 |
| 4.5 | General Safety | 8 |
| 5.0 | Changing the Vial Holder | 8 |
| 6.0 | Operation | 10 |
| 6.1 | Control Panel | 10 |
| 7.0 | Blending and Pulverizing | 11 |
| 7.1 | Mixing | 11 |
| 7.2 | Grinding | 11 |
| 8.0 | Error Messages | 11 |
| 8.1 | Lid Error | 11 |
| 8.2 | Run Fault | 11 |
| 9.0 | Maintenance | 12 |
| 10.0 | Accessories | 12 |
| 11.0 | Vial Reference Table | 13 |
| 12.0 | Warranty | 14 |
| 12.1 | Product Specifications | 14 |
| 12.2 | To Arrange a Return Shipment | 14 |
| 13.0 | Instrument Disposal | 15 |
| 14.0 | Contact Us | 16 |

1.0 INTRODUCTION

The BM-200 Mixer/Mill® is an efficient, compact laboratory mill designed for small-scale sample preparation. It is very effective pulverizing samples in the 1 gram range, or mixing product samples with volumes up to 3 ml.

Functionally described as ball mill, this Mixer/Mill shakes containers back and forth thousands of times a minute. The vial, which contains a sample and one ball, is shaken in a complex motion that combines back-and-forth swings with short lateral movements, each end of the vial describing a figure-8. With each swing the ball impacts against one end of the vial, simultaneously milling the sample to a powder and blending it.

Sample grinding is often performed manually with a mortar and pestle, an approach that is not practical for day-to-day screening since manual grinding of rock-like material is slow, and re-use of mortars and pestles may lead to cross-contamination.

Ideal for pulverizing the toughest rocks, minerals, cement and ceramics, rapidly reducing samples to analytical fineness, blending powders, and making emulsions. Finely grinding the sample increases the surface area to improve acid dissolution for ICP, AA, and pellet pressing or fusion bead for XRF.

The features include: modern design, operating commands through a digital timer, large clear lid for visibility of sample loading area, safety interlock, interchangeable vial holders and the clamp orientation makes it easy to load/unload samples. A choice of steel, agate, tungsten carbide, and plastic vials are available for purchase. Interchangeable vial holders for each vial type are sold separately.

Operation is simple: the vial is secured in a clamp, and the lid closed. The controls are checked for the proper running time, rate, and the RUN button pushed. When the run is complete, the lid is lifted, and the vials are unclamped.

NOTE: PLEASE DO NOT OPERATE THE BM-200 MIXER/MILL® UNTIL YOU HAVE READ THESE INSTRUCTIONS AND ARE FAMILIAR WITH ITS CONTROLS AND CLAMP MECHANISM. THE BM-200 MIXER/MILL® IS INTENDED FOR USE ONLY BY QUALIFIED AND TRAINED PERSONNEL.

2.0 SPECIFICATIONS

| | |
|-----------------------------------|---|
| Type of Mill: | Ball Mill |
| Display: | Digital |
| Grinding Mechanism: | Grinding balls of stainless steel, tungsten carbide, or agate. |
| Dimensions | 15 in. (38 cm) long x 8 in. (20.5 cm) wide x 11 in. (30 cm) high. |
| Weight: | 23 lbs. (10.4 kg) with external power supply. |
| Capacity: | One polycarbonate vial (cap with steel inserts), one polycarbonate vial (cap with tungsten carbide inserts), one agate vial, or four polyethylene vials. |
| Clamp Speed: | Fixed Speeds (rpm): 750, 2000, 3000, 3500. |
| Electrical Specifications: | CE approved. 115V/230V, 60/50Hz. CSA approved. |
| Circuit Breaker: | Same as ON/OFF Switch. |
| Power Cord: | 115V/60Hz model: 3-prong grounded plug supplied. 230V/50Hz model: 2-prong European plug supplied. Operator is responsible for supplying alternate line cord/plug. |
| Safety Features: | Interlock prevents mill from running if lid is open. |
| Run Timer: | Maximum 5 minutes. |
| Motor: | 1/7 HP. Maximum speed 4200 rpm. |
| Environment: | For indoor use only at a maximum altitude of 6600 ft. (2000 m). Operate at ambient conditions between 40°F (5°C) and 104°F (40°C), with maximum relative humidity 80% below 88°F (31°C) decreasing linearly to 50% at 104°F (40°C). Main supply voltage fluctuations up to 10% of nominal voltage (115 or 230 volts AC RMS). Pollution degree 1: none or only dry, conductive pollution occurs. |

3.0 UNPACKING

Inspect the exterior of the packing box and report any visible damage to the carrier. Remove all packing documents from the exterior of the box, and save them for your records. Open the top of the shipping box. Remove the packing material and accessories, and gently lift out the BM-200 Mixer/Mill®. Visually check the mill for any damage that may have occurred during shipping. Open the lid, remove packing from around the clamp mechanism and cut the zip ties securing the clamp arm. **Tilt the cabinet and remove the two shipping red bolts on the bottom.** They hold the floating baseplate to the cabinet for shipping. Check the packing list to see that there are no parts missing, and inspect the accessories. We recommend storing the packaging materials in the event there is a need to return the unit for warranty service or repairs.

Vials and vial holders are necessary for processing samples but must be purchased separately. The full range of vials and accessories for the BM-200 Mixer/Mill® is described in this manual, or Cole-Parmer.com.



Figure 1 – Front View

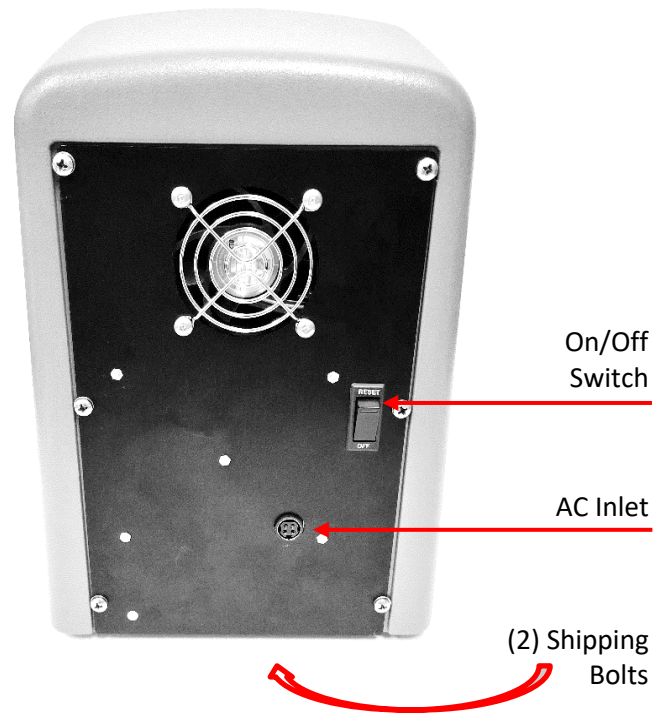

Figure 2 – Back View

NOTE: Before operating, remove the shipping two red bolts from the bottom of the BM-200 Mixer/Mill; otherwise the mill may be damaged. The two red bolts should be reinserted if the unit is ever to be shipped or transported.

4.0 SETTING UP

The BM-200 Mixer/Mill® weighs 23 pounds (10.4 Kg). The lid opens from the front with the handle in the center. The AC Inlet and On/Off switch are located on the back of the cabinet, as shown in Figure 2. The control panel is fixed to the front side of the unit (Figure 1).

4.1 Electrical Connection

The detachable power cord should be plugged firmly into its inlet, then into an electrical outlet. Make sure that the electrical outlet is easily accessible in case it becomes necessary to unplug the unit. For 115V/60HZ use, a 3-prong outlet. The 230V/50HZ BM-200 Mixer/Mill power cord has a standard European 2-prong plug, but modification by the user may be necessary to meet local electrical codes.

4.2 Cabinet Set-Up

To open the lid, grasp the gray handle and raise the lid to its full upright position. Allow the lid to rest against the cabinet in its open position. To close, grasp the gray handle and lower the lid until it is fully closed.

4.3 Standard Safety Features

Clamp Locking Tab: Place a vial holder in the clamp. Note, the Agate and Tungsten Carbide vials have different holders. **The holder must be inserted in the Clamp with the proper Orientation, as shown in Figure 3).** Push the Holder Cover down and close the clamp arm by pushing it down then pressing the locking Tab inwards until it clasps the clamp arm. Stretch the safety ring around the clamp arm knob to secure the vial in holder. To remove vial (or holder), unclasp the safety ring and locking tab from the clamp arm and extend the arm to the open position.

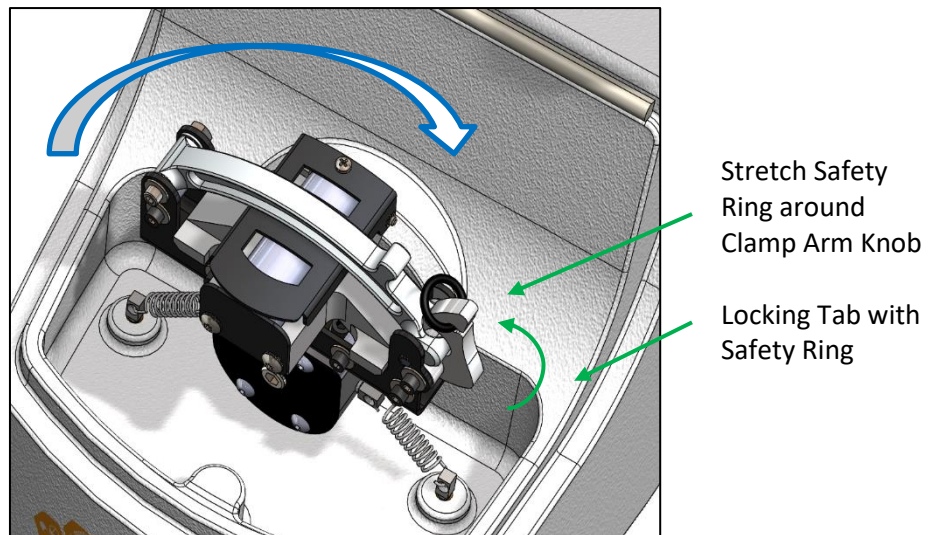

Figure 3 – The Clamp Locking Tab

4.4 CE Safety Features

CE directives require that electricity to the motor and timer be interrupted whenever the lid is open, and that the clamp must stop completely before the lid is opened.

Safety Interlock: If the RUN button is pressed while the lid is open, the BM-200 Mixer/Mill will not start. During operation, if the lid is opened, the motor will immediately stop, and movement of the clamp mechanism will cease.

4.5 General Safety



Caution: Every effort has been made to ensure the BM-200 Mixer/Mill operates at a moderate noise level. The intensity of noise is directly impacted by the type of grinding vial, type of balls, run speed (e.g. 3500 rpm) and sample hardness. Ear protection is recommended.

5.0 CHANGING THE VIAL HOLDER

The clamp mechanism is the most critical component of the mill. Sample vial holders must be held securely in the clamp during operation to prevent damage and leakage.

Only use a vial holder that is designed for the appropriate vial. See Table A. below for a list of the vial holders and suitable vial types.



Figure 4 – 1211 Vial Holder
(5ml Polyethylene Vials)

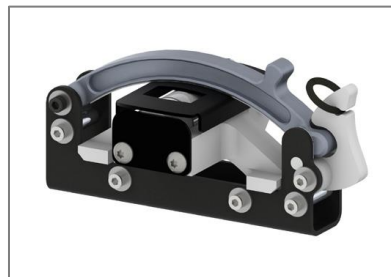

Figure 5 – 1217 Vial Holder
(Agate Vial)

Table A.

| Holder | # Vials and Vial Size | Vial Set | Grinding Balls or Beads |
|--------------------|---------------------------------|-------------------------|--|
| 1211 (04500-07) | Holds four polyethylene vials | 2241R-PEF (04500-37) | 6.35 mm Steel or 6 mm Zirconia 2154 (04575-44) or 2186 (04575-60) |
| 1215 (04575-32) | Holds one Stainless Steel vial | 5005 (04576-25) | 7.9 mm Stainless Steel (included with vial) |
| | Holds one Tungsten Carbide vial | 5006 (04576-26) | 7.9 mm Tungsten Carbide (included with vial) |
| 1217 (04575-34) | Holds one Agate vial | 3120 (04575-93) | 6.35 mm Agate |

5.0 CHANGING THE VIAL HOLDER (Cont'd)

The vial holder can be placed or removed from the clamp mechanism with or without sample loaded vials, as shown in displayed in Figure 6.

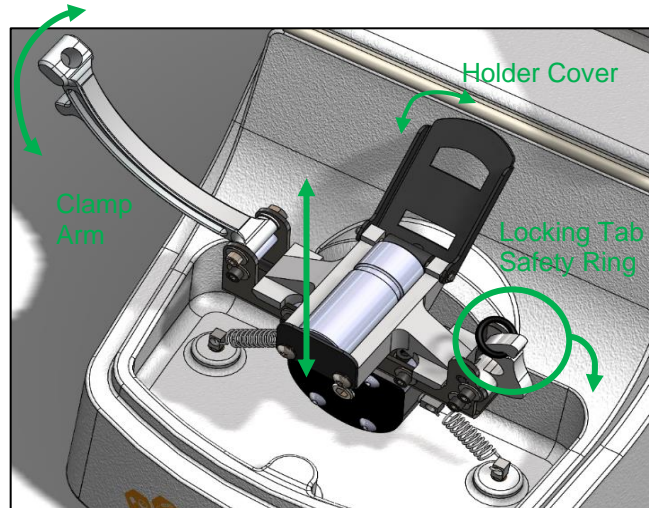

Figure 6 – Inserting (Removing) Vial Holder

- 1) Unclasp the safety ring and locking tab from the clamp arm.
- 2) Fully extend the clamp arm to the open position.
- 3) Insert the vial holder into the clamp and carefully press down until it fits snug in the cradle.
- 4) Place the vials into the holder.
- 5) Push the Holder Cover down.
- 6) Close the clamp arm, pushing it down then pressing the locking tab inwards until it clasps the arm.
- 7) Stretch the safety ring around the clamp arm knob to secure the vials in holder.
- 8) Program a run as described in section 6.1.

6.0 OPERATION

NOTE: Never run the BM-200 Mixer/Mill with the clamp arm unfastened or not properly secured. Damage and leakage will result.

6.1 Control Panel

6.1.1 Digital Timer

To set a programmed run use the plus (+) and minus (-) buttons to adjust the runtime. Press the plus button (+) to increase the time in 5-second increments or press the minus button (-) to decrease the time in 5-second increments. Maximum runtime is 5.00 min.

To set the rate use the plus (+) and minus (-) buttons to adjust the run speed. Press the plus (+) and minus (-) buttons to set the rate at the following fixed speeds to 750 rpm, 2000 rpm, 3000 rpm, or 3500 rpm.

Push the Run button to begin a programmed run. The timer counts down in 1-second increments, showing the time left in the run. When the timer reaches zero and the motor shuts off, the timer will display RUN COMPLETE. The safety interlock switch prevents the BM-200 Mixer/Mill from running if the lid is open.

To have the unit pause during a run and retain the timer setting, push the PAUSE button. The motor will shut off and PAUSED will appear in the display window. To resume the run, close lid and push RUN; the timer will briefly display the exact number of seconds left in the run and then continue to count down in 1-second increments. To abort the run, push STOP; RUN ABORTED will appear in the display window.



Figure 7 – Control Panel

7.0 BLENDING AND PULVERIZATION

7.1 Mixing

Mixing is commonly done in a 5 ml plastic vial using a stainless steel ball or ceramic bead. Depending on the sample (pre-ground) and amount of material used for the mixing process, vials with one or two balls may be more efficient.

7.2 Grinding

A typical grinding load is about 40% of the vial's volume. If a sample is not being ground fine enough, one can a) decrease the amount of sample, b) increase grinding time, or c) add a grinding aid. Wet grinding keeps the sample from caking and will yield a smaller particle size, but there are drawbacks: 1) an extra drying step is required, 2) the fluid used for wet grinding must be chosen carefully not to alter the sample or attack the container, and 3) not all the vials are leak proof. The 5005 Stainless Steel vial, 5006 Tungsten Carbide vial and all plastic vials are more or less watertight.

Dry grinding is the simplest approach and is most often done in the polycarbonate containers with steel or tungsten carbide cap-lined inserts.

For samples that cake during mixing, a slurry with water or 3650 Vertrel™ XF (fluorocarbon fluid) may be helpful. Water may be dried out afterwards by heating vials in a very low temperature oven. If caking is due to static charges, a small amount of 3642 Cellulose can be used as a grinding aid.

8.0 ERROR MESSAGES

8.1 Lid Error

If the lid interlock fails while the BM-200 Mixer/Mill is running, the unit will stop running and the screen will display a "LID OPEN" message. The timer will maintain the time remaining in the run. To restart, close the lid and press the RUN button to finish the run. To end the run and reset the timer, press the STOP button. The "LID OPEN" message will disappear once the lid is closed.

8.2 Run Fault

If a "RUN FAULT" message appears on the display screen, this indicates the BM-200 Mixer/Mill is not operating within an acceptable range of the set rate. Press the STOP button to discontinue operation and contact Cole-Parmer.

9.0 MAINTENANCE

NOTE: Always unplug the BM-200 Mixer/Mill before any cleanup or maintenance work.

The BM-200 Mixer/Mill® has been designed to provide trouble-free operation over a long period of time. To assure proper performance, the most important factor is cleanliness. It is a good laboratory practice to clean up any spills immediately.

The cabinet is made primarily of painted plastic. The lid is a clear formed polycarbonate. The interior as well as the exterior surfaces of the unit are designed to be easily cleaned in case of a sample spill. To maintain the overall appearance of the unit, periodically wipe the exterior and interior of the BM-200 Mixer/Mill with a mild window cleaner or similar product (use a soft non-abrasive cotton cloth).

10.0 ACCESSORIES FOR THE BM-200 MIXER/MILL®

Grinding Balls

2154 (04575-44) Grinding Balls 1/4 inch (6.35 mm)

Made of 440C stainless steel. Used with 2241R-PEF 5 ml vial.

2186 (04575-60) Grinding Balls 15/64 inch (6 mm)

Made of zirconia. Used with 2241R-PEF 5 ml vial.

3118A (04577-22) Grinding Balls 1/4 inch (6.35 mm)

Made of agate. Used with 3120 Agate vial.

5005B (04577-61) Grinding Balls 5/16 inch (7.9 mm)

Made of 440C stainless steel. Used with the Stainless Steel 5 ml vial.

5006B (04577-62) Grinding Balls 5/16 inch (7.9 mm)

Made of tungsten carbide. Used with the Tungsten Carbide 5 ml vial.

Vial Holders

1211 (4500-07) Holder for 2241R-PEF (5 ml) vials (only)

Holds 4 vials.

1215 (04575-32) Holder for 5005 Stainless Steel vial or 5006 Tungsten Carbide Vial Set

Holds 1 vial.

1217 (04575-34) Holder for 3120 Agate Vial Set (only)

Holds 1 vial.

10.0 ACCESSORIES FOR THE BM-200 MIXER/MILL® (Cont'd)

Vials, and Vial Sets

2241R-PEF (04500-37) Frosted Polyethylene Vial

5 ml frosted polyethylene vial with screw-on polyethylene cap with O-ring. ½ in. diameter x 2 in. long (12.7 mm x 50.8 mm). Holds one or two 1/4 in. (6.35 mm) steel grinding ball; mixing load per vial 3 ml.

3120 (04575-93) Agate Vial Set

3.5 ml agate vial in a Delrin vial case 7/8 in. diameter x 2 in. long (22.2 mm x 50.8 mm). Includes one 1/4 in. (6.35 mm) agate grinding ball (3118A). One flat gasket for lid. Grinding load 0.5 - 1.0 g; mixing load 2 ml. **Agate is fragile, it should not be handled carelessly. Vial set must be sold without a warranty against breakage.**

5005 (04576-25) Stainless Tool Steel Vial Set

3/4 in. diameter x 2 1/8 in. long. Includes two slip-on Delrin caps with stainless steel inserts, four polycarbonate center cylinders, and one 5/16 in. (7.9 mm) stainless steel ball. Two O-rings for center cylinder. Two flat gaskets for caps. Grinding load 0.5 - 1.5 g.

5006 (04576-26) Tungsten Carbide-Lined Vial Set

3/4 in. diameter x 2 1/8 in. long. Includes two slip-on Delrin caps with tungsten carbide inserts, four polycarbonate center cylinders, and one 5/16 in. (7.9 mm) tungsten carbide ball. Two O-rings for center cylinder. Two flat gaskets for caps. Grinding load 0.5 - 1.5 g.

5006C Replacement Polycarbonate Center Cylinder

Disposable polycarbonate center cylinder; for 5005 and 5006 vial set. Includes two O-rings.

11.0 Vial Reference Table

Table B.

| Part | Size | Vial Type | Media | # Balls | Purpose | Holder | # Vials | Speed |
|-----------|--------|---------------------------------|------------------|------------|------------------|--------|---------|------------|
| 2241R-PEF | 5 ml | Frosted Polyethylene | Zirconia, Steel | One or Two | Mixing, Emulsion | 1211 | 4 | Up to 3500 |
| 5005 | 5 ml | Polycarbonate, steel caps | Steel | One | Rock, Minerals | 1215 | 1 | Up to 3500 |
| 5006 | 5 ml | Polycarbonate, tungsten carbide | Tungsten Carbide | One | Rock, Minerals | 1215 | 1 | Up to 3500 |
| 3120 | 3.5 ml | Agate vial | Agate | One | Rock, Minerals | 1217 | 1 | Up to 3500 |

12.0 WARRANTY

Cole-Parmer® guarantees its products against defects in materials or workmanship for three years from the date of original shipment. Repairs, replacements, or parts are guaranteed for 30 days or for the remaining original warranty period (whichever is greater) for the item that was repaired or replaced. Items not produced by Cole-Parmer® carry the manufacturer's warranty only.

The warranty excludes wear parts. These are parts that wear out through use and must be replaced periodically for proper operation. BM-200 Mixer/Mill wear parts include the following which can be changed by the user.

- 21609 Spadebolt
- 52160 Spring
- 50157 Vibration Mount
- 51702 Clamp Arm Safety O-ring

In the event that these or other parts require service, please contact Cole-Parmer to arrange a return shipment.

The customer pays return freight for warranty claims. If the warranty claim is valid, Cole-Parmer® will pay return freight to the customer. However, Cole-Parmer® reserves the right to judge whether a malfunction during the warranty period is due to defects in materials or workmanship, or to wear, negligence, or misuse.

12.1 Product Specifications

Every effort has been made to provide complete and accurate product operation and information in this manual. However, since specifications are subject to change without notice, changes may be made from time to time to improve the performance of the product.

12.2 To Arrange A Return Shipment

We want you to be satisfied with your purchase from Cole-Parmer®. Please bring any problem to our attention, but please DO NOT RETURN any item before contacting us for a Return Authorization Number and instructions. Unauthorized returns will be refused. The cost for all return transportation is the responsibility of the customer. Credit for returned merchandise will be issued only after goods have been received and inspected. Returned goods are subject to a 25% restocking charge.

13.0 INSTRUMENT DISPOSAL

In accordance to the EU Directive 2012/19/EU covering Waste Electrical and Electronic Equipment, all equipment with the disposal symbol must not be disposed of with general waste. (See Figure 8)

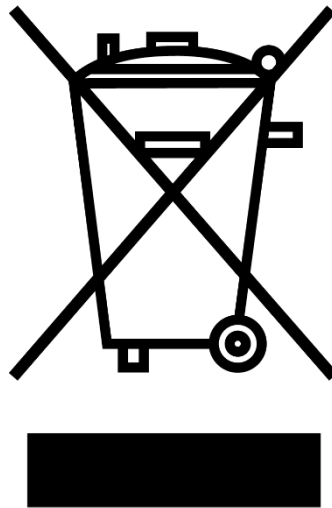

Disposal Label is located on the back of unit.

Figure 8 – Disposal Symbol

Throughout the European Community, guidelines regarding disposal regulations may vary from territory to territory. Please contact the national legislation or local authority for more information on proper disposal of all equipment with this symbol.

14.0 CONTACT US

Repair Service

Phone: 1.732.623.0465

Cole-Parmer
65 Liberty St
Metuchen, NJ 08840
US

Attn: Service and Repair

Please include RA Number on the shipping label.

Cole-Parmer®

an Antylia scientific company

625 East Bunker Ct.
Vernon Hills, IL 60061
US

US

T: +1.800.323.4340 or
+1.800.323.4340

E: sales@antylia.com

W: coleparmer.com

Canada

T: +1.514.355.6100

E: info@antylia.ca

W: coleparmer.ca

China

T: 86.21.5109.9909

E: sales@antylia.com

W: coleparmer.cn

France

T: +33 (0) 1486 37800

E: fr.sales@antylia.com

W: coleparmer.fr

Germany

T: +49 (0) 9377 92030

E: de.sales@antylia.com

W: coleparmer.de

India

T: +9122 61394444

E: info@coleparmer.in

W: coleparmer.in

Italy

T: +39 (0)2 84349215

E: it.sales@antylia.com

W: coleparmer.it

UK

T: +44 (0) 1480 272279

E: uk.sales@antylia.com

W: coleparmer.co.uk

Other

T: +1.847.549.7600