

Cole-Parmer®

SM-300 Mixer/Mill

Rock and Mineral Grinder (Ring and Puck Mill) for Spectroscopy Applications

Operation Manual

For 115V (41010-83) and 230V (41010-84)

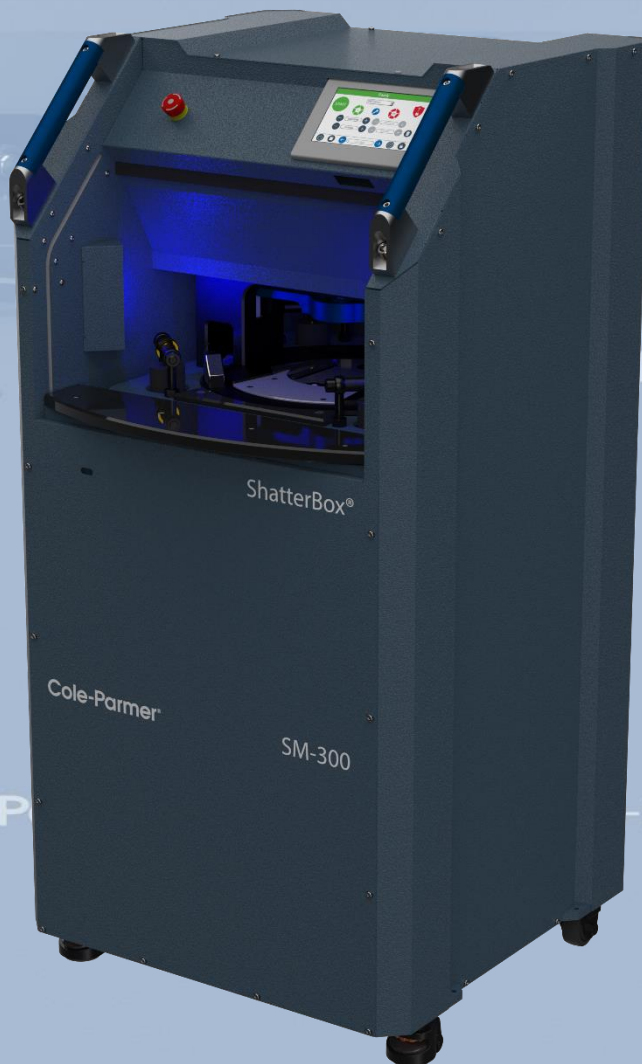

SPEX SamplePrep is now part of Cole-Parmer®.

The Cole-Parmer® SM-300 Shatterbox was formerly known as SPEX 8550 Shatterbox.

Over the years, we've acquired many high-quality and reputable brands. After many years of continual growth, we realize our brands are all as brilliant as each other. Rather than have a portfolio of complementary brands, we felt consolidating them under one world-class brand name enabled us to offer a single and significant brand experience. Through one brand we can speak in one voice through our team of experts who provide support in product selection, usage and troubleshooting to empower laboratories to run efficiently throughout the world.

Same Great Quality!

One World-Class Brand Name!

Copyright 2023 by Cole-Parmer

All rights reserved. No part of the work may be reproduced or transmitted in any form or by any means, electronic or mechanical; including photocopying and recording, except as may be expressly permitted by the 1976 Copyright Act or in writing from the publisher. Requests for permission should be addressed in writing to Cole-Parmer, 65 Liberty Street, Metuchen, NJ 08840.

Index

Index	3
Introduction	5
Historical background	5
The SM-300 ShatterBox.....	6
Accessories	8
Main features	8
Precautions	10
Installation	11
Location	11
Unpacking.....	12
Connection - electrical	13
Connection – exhaust	14
Leveling casters.....	14
Setting up	15
Questions ?	15
Choice of the grinding container	16
Material.....	16
Size	17
How the unit works	19
Grinding methods.....	19
Door operation	19
Clamping the dish	19
Grinding motion	19
Using the SM-300 ShatterBox	20
Operation of the safety door	20
The main running screen	22
Loading a program	24
During a grinding	25
A general grinding	25
Programming the SM-300 ShatterBox (advanced)	27
Unlocking the advanced mode	27
Managing grinding methods	28
Preparing a grinding program	28
Grinding steps.....	29
Global parameters	30
Options	30
Special parameters	32
Accessing the Special parameters	32
Parameters description	33
Dish calibration procedure.....	35

Grinding troubleshooting	36
Unit does not turn on.....	36
Unit does not run	36
Door remains locked.....	36
Grinding container locked up, won't grind	36
Excessive vibration, unit "walks"	37
Locking failed	37
Periodic inspection	38
Warning	38
Inspection schedule table.....	38
Service operations	39
Warning	39
Top panel removal.....	40
Front panel removal	41
Door removal	42
Back panel removal	45
Firmware and program transfers.....	46
Preset programs.....	46
Backup or restore by USB.....	46
Technical specifications.....	48
Warranty	49
Product changes.....	49
Return shipments	49
Contacting SPEX	50

Introduction

Congratulations on your acquisition of the SM-300 ShatterBox, from Cole-Parmer. This section intends to introduce the reader to basic grinding principles and to familiarize him or her to the SM-300 ShatterBox.

Historical background

Since its introduction in the 1980's, the ShatterBox has become the most popular "swing mill" in America. Now as then, it remains the most efficient way to pulverize up to 100ml in volume (or 100g in weight) of brittle material to analytical fineness. The unit has many advanced features, including a touchscreen with programmable timer, an automated clamp, a safety-interlocking automated door, and horizontal grinding container insertion/removal.

The SM-300 ShatterBox

General view

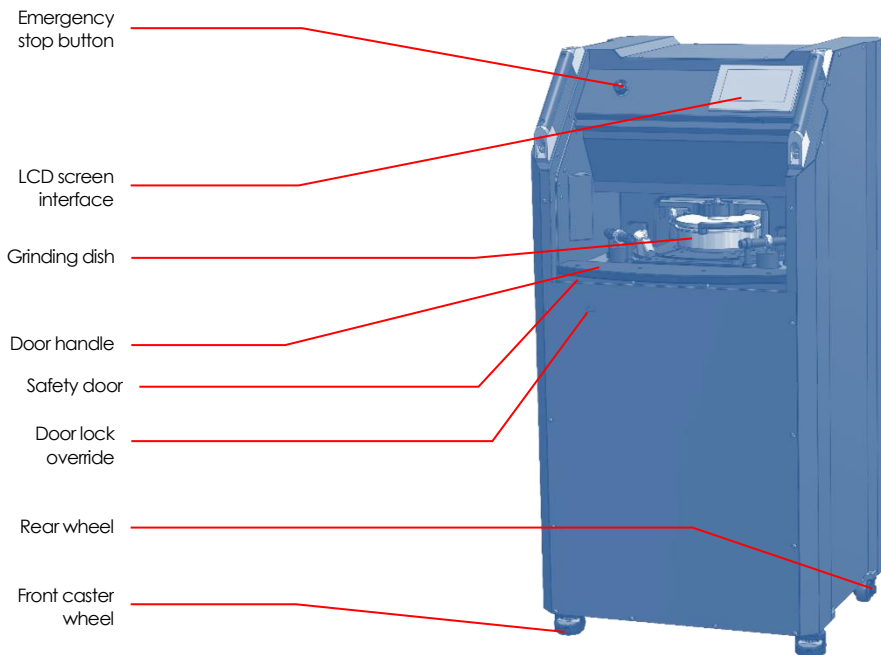

Working principle

The SM-300 ShatterBox swings a dish-shaped grinding container, with a puck and (often) a ring inside, in a tight high-speed circle; the sample is quickly crushed between the wall and floor of the container and the moving puck/ring grinding elements. Smaller grinding containers and those made with ceramics have a puck-shaped grinding element; larger containers add a ring. Most grinding containers are fitted with a gasket to prevent sample loss during grinding.

Since grinding containers are chosen for specific tasks, there is no “standard” SM-300 ShatterBox grinding container. In general, grinding times range from two to five minutes, with resultant particle size well below 100 μ m, and in some cases 5 μ m. Typical samples include cements, soils, ceramics, slag, rocks, and ores, but the SM-300 ShatterBox has also ground sulfur pellets, dried marsh-grass, pharmaceuticals, and many other materials. To maximize grinding capability and minimize

contamination, grinding containers are available in hardened steel, tungsten carbide, alumina ceramic, and zirconia ceramic. The full range of SM-300 ShatterBox grinding containers are on our website: coleparmer.com

Automated dish holder

Unlike some other units, this mill provides a simple and efficient system to automatically retain (or "clamp") the dish. When the user has slid the dish in its recess, closed the safety door and pressed Start, a motorized system applies a downward pressure onto the dish lid, thus ensuring that the lid is secured in place, as well as the base of the dish itself.

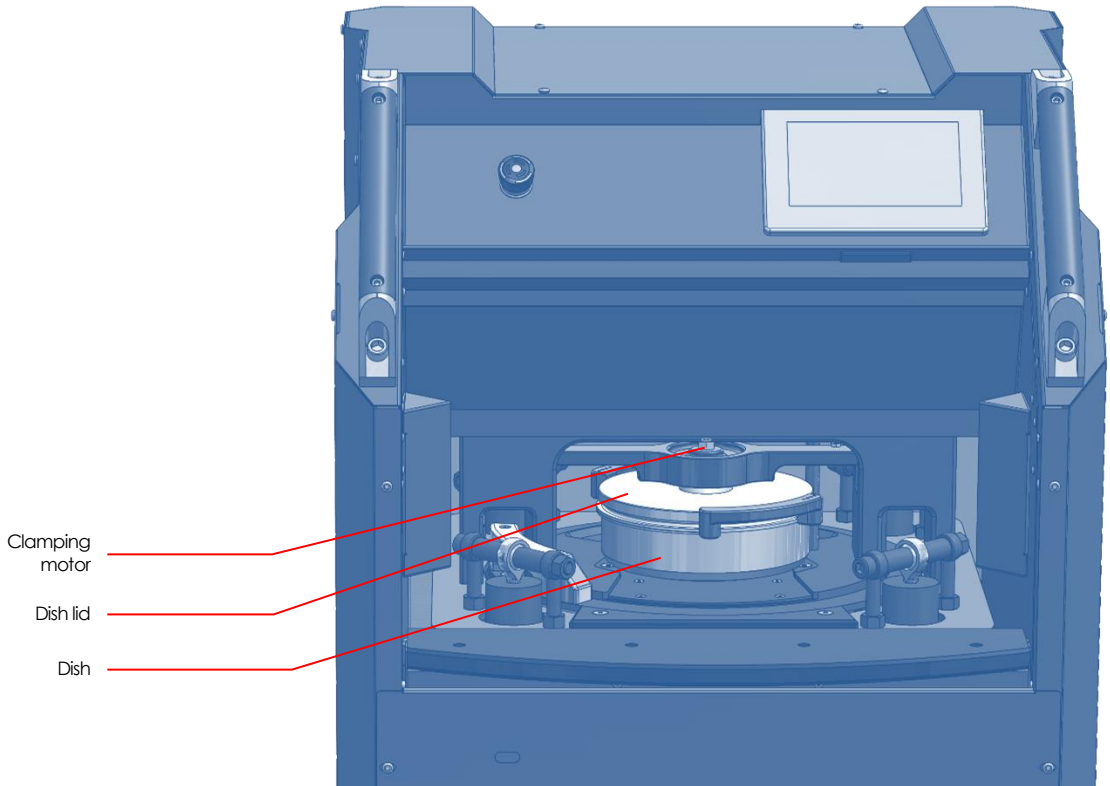

Accessories

The SM-300 ShatterBox requires the use of a dish with a handle assembly. For existing dishes without handle assembly, the corresponding handle assembly may be purchased separately and secured to the dish.

Available Grinding Dishes:

Dish and handle assembly <i>(Required for SM-300)</i>	Dish (grinding container) description	VPN	Handle VPN <i>(May be purchased for existing dish)</i>
8501-H	Hardened Steel	8501	8511-01
8504-H	Tungsten Carbide	8504	8511-04
8505-H	Alumina Ceramic	8505	8511-05
8506-H	Zirconia	8506	
N/A	Small Hardened Steel	8507	8507R (rack)
	Small Tungsten Carbide	8508	
8521-H	Large Hardened Steel	8521	8511-21

NOTE: *In practice, the sample capacity of any particular grinding container depends on the properties of the sample, particle-size requirements, and other considerations.*

Main features

Accuracy

- Entirely automated
- Electronically controlled, fully reproducible grinding methods

Safety

- Integrated dual-locking safety door with glass viewport
- Redundant dish position sensing
- Real-time monitoring of clamping force
- Dual monitoring of the grinding motor speed
- Sound-insulated steel cabinet
- Lockable caster wheels

Versatility

- Stores up to 10 different grinding programs
- Fully customizable grinding methods
- USB connectivity
- Ethernet (wired network) port

- Accepts various grinding dish types

Productivity

- Automated door opening after a grinding operation
- Automated dish clamping

Durability

- Sturdy industrial-grade modular electronics
- Robust IP65 rated industrial interface
- Dedicated PLC-based programming
- Low maintenance

Simplicity

- Easy installation, easy use
- Single-phase power, no separate power supply
- Intuitive touch-screen color LCD graphics interface
- Easy icon navigation
- Multilingual interface
- Easy component access
- USB-upgradeable firmware
- 1-year limited warranty



Precautions



Pinch point

This unit features a door that opens automatically. Do not touch the unit after grinding, until the door has fully opened.



High voltage

Disconnect power cord before attempting any cleaning, maintenance or repair operation.

Be careful that no liquid infiltrates into the unit's casing.



Heavy instrument

It is advisable that at least two persons roll this instrument to avoid injuries. Do not drop instrument. Crated unit should only be moved with mechanical assistance (lift truck or pallet jack).



High noise levels

This device emits noise up to 80 dB.

Wear appropriate hearing protection.



General hazards

Never turn the unit on or run a grinding process with casing panels removed. Risks of electrocution. Mechanical hazards due to high velocity and strong pinching motions.

Installation

Please read the following section for proper commissioning of your instrument. Do not hesitate to contact Cole-Parmer® with any question you might have with this crucial step.



IMPORTANT: *It is advisable that several persons carry this instrument to avoid injuries. Do not drop instrument.*

Location

Keep the shipping crate upright; it is advisable that several persons roll the instrument to avoid back injuries. Crated unit should only be moved with mechanical assistance (lift truck or pallet jack).

When positioning the crate for opening, please note that one of its side panels will deploy into a 1.5 m-long (5 ft) ramp, so proper placement and clearances must be planned.

IMPORTANT: *The instrument can be carried by its bottom plate, or by the two large handles on each end of the unit top. The safety door handle shall NOT be used to carry the instrument.*

Floor requirements

This unit is a floor-standing unit; the floor must be rigid, reasonably level, and able to safely withstand a weight of 250 kg (550 lbs).

A perfect leveling of the floor is not critical (and can be helped by adjusting the caster heights), but a *rigid* floor with properly adjusted casters is important to the good operation of the unit.

Safety and working clearances

When this unit operates, it shakes in place, and so appropriate clearances must be kept all around the unit.

Our minimum recommendations are:

- 5 cm (2 in) at the left side
- 5 cm (2 in) at the right side
- 10 cm (4 in) at the back

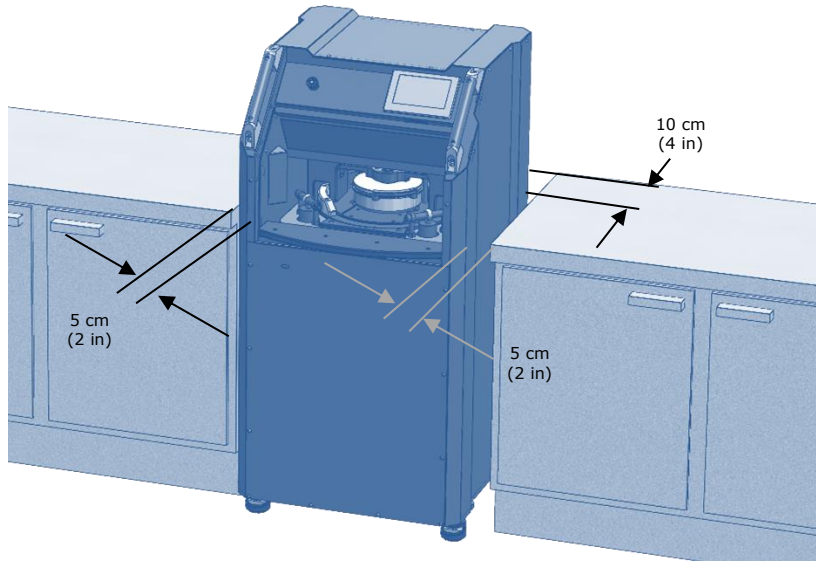

Obviously, a clear access at the front of the unit is needed, for the operator to work the controls and load/unload the grinder.

Unpacking

The SM-300 ShatterBox mechanism and its cabinet are shipped assembled, and carefully packed to avoid damage during shipping. Any visible damage to the shipping container should immediately be reported to the carrier. If there is no visible damage, remove all packing documents from the exterior of the box, and after completion of your inspection, file in your records.

Refer to separate unpacking instructions for step-by-step details.

Retain the shipping crate in case there is ever a need to return the SM-300 ShatterBox for service.

Crate contents

The instrument comes with its essential accessories. In addition to optional items you might have ordered, the box should contain:

- 1 SM-300 ShatterBox (main grinder unit)

- 1 instruction manual (this booklet)
- 1 power cable
- 1 USB memory stick
- 1 wrench (10 mm)
- 1 set of Torx keys

Additionally, if you have ordered an optional dish, you will find:

- Grinding dish with handle assembly
- Puck (and ring, if applicable)

Connection - electrical

Plug the cabinet power cord into an approved electrical outlet using the included power cable.

Note that the SM-300 ShatterBox nominal voltage is **either** 115 VAC (60 Hz, 10 A) **or** 230 VAC (50-60 Hz, 5 A). These versions **cannot be switched without hardware replacements.**

NOTE: *If the included cable needs to be replaced to suit local electrical codes, the user should refer to the rating plate located to the back of the unit and consult with an electrician before attempting any electrical connection.*

Connection – exhaust

A standard 3-in (76 mm) outlet allows the unit to be connected to your dust extraction/exhaust system.

To connect it, a safety screw must be removed to allow for the blade of the blast gate to be pulled down in open position. We suggest using a standard flexible 3-in duct hose with worm-drive clamps to link the unit with your air extraction system.

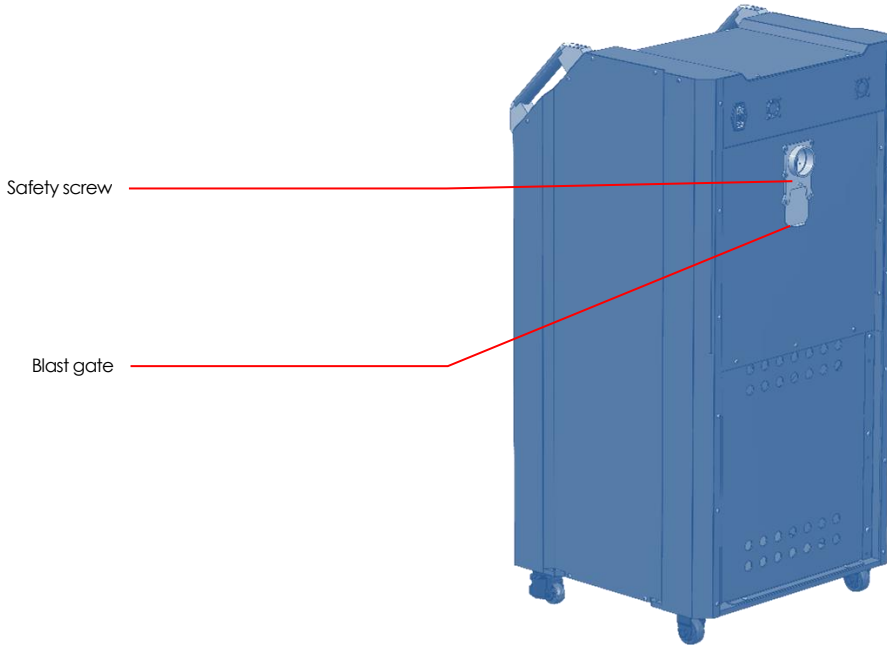

If the air extraction system needs to be disconnected, we recommend to re-close the blast gate, and secure its blade with the safety screw.

NOTE: Although this connection is optional, we recommend using it, to remove any dust expelled when unlocking the dish, since the contents may be under pressure.

Leveling casters

Once the unit is set in position, use the adjustment nuts on the front feet to level the unit while completely lifting the front portion. It is important that the unit does not rest on its front wheels when finished. (The wheels should turn freely after correct leveling.)

To lift the front of the unit, use the provided 10-mm wrench and turn the caster nut in the direction shown below. (A finger adjustment with the orange knob is not sufficient.)

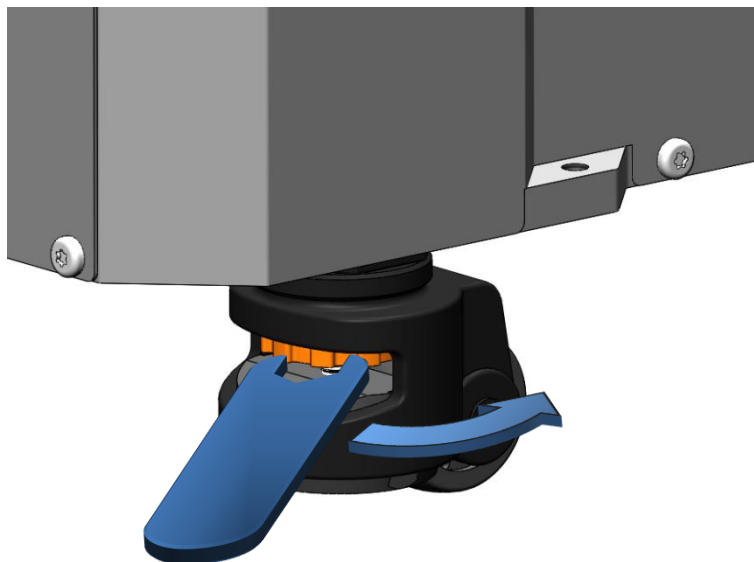

IMPORTANT: Always lift the unit with the casters leveling nut before operating the SM-300 ShatterBox. The grinder should be fully stabilized as described above, so that it rests firmly on all four legs.

Setting up

After the initial unpacking and setup of the SM-300 ShatterBox, you are ready to prepare the unit for use.

As you prepare the SM-300 ShatterBox to grind samples, become familiar with the grinding dish/container you will use. The sample is placed in a container with a puck (and sometimes a ring); then the container is swung in a tight circle while the puck (and ring) crushes the sample against the bottom and wall of the container. Most of the ShatterBox containers have an O-ring or gasket that prevents leakage during grinding. Grinding containers are available in several sizes and in a range of materials to minimize objectionable contamination: hardened steel (VPN. 8501, 8507, and 8521), tungsten carbide (VPN. 8504, 8508), alumina ceramic (VPN. 8505), and zirconia ceramic (VPN. 8506).

Before actually operating your new SM-300 ShatterBox, it is important that you become familiar with its special features. This section explains in detail how each part of the SM-300 ShatterBox works.

While familiarizing yourself with the operation of the SM-300 ShatterBox you may wish to use a grinding container without its puck/ring, and without sample.

Questions ?

Should you have any question regarding the proper installation and start-up of your instrument, please contact Cole-Parmer (see information on page 50) for assistance.

Choice of the grinding container

There are at present ten different ShatterBox grinding containers in five different materials and four sizes; while each of the ten has a puck-shaped grinding element or a puck and ring, each has different requirements for sample size and/or grinding time. Consequently, the following instructions are general in nature.

Material

Every grinding-container material has its benefits and drawbacks. Some will contaminate a sample fairly heavily, others lightly; some will grind a sample more rapidly than others, while some are more prone to breakage; and there are cost considerations. Detailed advice on choosing the proper grinding container can be found in the *ShatterBox Accessory Manual*.

Contamination

Often the prime consideration in choosing the container material is whether it will contaminate the sample with elements of interest in the analysis. Thus, steel mills looking for iron in slag will choose tungsten carbide over steel, while a geochemist doing trace-element determinations in igneous rocks might avoid both zirconia ceramic for its major elements Zr, minor elements Hf and Y, and tungsten carbide for the small amounts of Ti, Ta, and Nb present.

Performance

The denser the grinding-container material, the more rapid the grinding. Tungsten carbide is the densest, followed by steel, zirconia ceramic, and alumina ceramic. Of these, steel is the most prone to wear if the samples are hard. The following summary of properties may be helpful:

- | | |
|-------------------------|--|
| Steel | is extraordinarily durable and relatively inexpensive, but subject to wear when used to grind hard materials (quartz and feldspar, glasses and slag). Grinds rapidly but tends to contaminate. Major element: Fe. Minor elements: Cr, C, Mn, and Si. |
| Tungsten Carbide | grinds very rapidly and wears well, but is subject to occasional breakage. It is harder than most samples other than the hardest refractories, but contaminates moderately. Major elements: W, C, Co. Minor elements: Ta, Ti, and Nb. |
| Zirconia Ceramic | is harder than steel and most slag and mineral samples, but is neither as heavy nor as hard as tungsten carbide. Grinds fairly rapidly with low contamination levels, and almost never breaks. Major elements: Zr. Minor elements: Hf, Y, Mg. |

Alumina Ceramic is harder than tungsten carbide, but is comparatively lightweight. It grinds fairly slowly with low contamination levels and is subject to fracture. Major elements: Al. Minor elements: Si, Mg, and Ca.

There are four sizes of ShatterBox grinding container: small, medium, large, and extra-large. To pick the correct size it is necessary to know the minimum amount of sample you have to grind, its approximate density, and the fineness of grind desired, as each may affect your final choice. The typical sample capacities of each container type are given below in grams, assuming a sample of the density of quartz sand, rock, etc. (approx. 2 to 3-1/2) and the requirement to pulverize the sample to around 325 mesh (44 microns). The sample capacity volume RANGE, which is much broader, is given in ml. If you are unsure which ShatterBox grinding container to select, consult our product specialists. You can also send your samples in for evaluation and test grinding.

- Small:** 8507 Small Hardened Steel and 8508 Small Tungsten Carbide grinding containers. Each has a puck-shaped grinding element. Typical sample capacity 8-15 grams, sample volume range 5-20 ml. Requires 8507R Rack to operate one 8507/8508 or three simultaneously.
- Medium:** 8505 Alumina Ceramic and 8506 Zirconia Ceramic grinding containers. Each has a puck-shaped grinding element. Typical sample capacity 20-40 grams, sample volume range 15-40 ml.
- Large:** 8501 Hardened Steel and 8504 Tungsten Carbide grinding containers. Each has a puck and ring. Typical sample capacity 25-75 grams, sample volume range 20-50 ml.
- Extra Large:** 8521 Large Hardened Steel grinding container, with puck and ring. Typical sample capacity 50-150 grams, sample volume range 30 - 100 ml.

The sample volume ranges given above are estimates, not absolute limits. The upward limit on the weight/volume of a given sample for a given grinding container is really determined by the point where the mill stops grinding the sample satisfactorily. This limit can vary with the type of the sample and its particle size. The lower limit on the size of the sample is usually reached when the sample becomes highly contaminated and is hard to recover. (If very little sample is ground there is a lot of direct contact between the grinding element or elements and the container, and under these conditions the tungsten carbide and ceramic grinding containers are more likely to become chipped.) Avoid grinding large chunks of sample, as these can either jam the grinding container or damage it; even if they grind satisfactorily, they will probably not grind consistently. We recommend reducing the feed size to at least 1/4" for the tungsten carbide and steel grinding containers, and to 1/8" for the alumina and zirconia ceramic grinding containers.

When developing a procedure for your combination of SM-300 ShatterBox and grinding container, try a sample size near the middle of the given range(s). Grind for two minutes in steel or tungsten carbide, or four minutes in alumina or zirconia. If grinding is not satisfactory but the sample is not caking, try increasing the

grinding time or decreasing the sample size, or both. If caking occurs, consult the *ShatterBox Accessory Manual* for information about grinding aids.

How the unit works

Grinding methods

The SM-300 ShatterBox comes pre-loaded with a basic grinding method that can be used as is, or can be customized. All grinding methods can be saved, renamed, deleted or copied, just like computer files. Only the preset method is protected to avoid accidental overwriting.

Each method allows the user to configure two grinding stages, each with their own speed (in RPM) and duration.

Door operation

Once a grinding dish has been installed and the user intends to start a grinding method, he or she must first manually close the door by sliding it all the way up, until it locks.

If the door was closed by mistake and the grinding method has not been started, the user can still un-lock the door through the LCD interface.

The safety door will automatically slide open again at the end of a grinding cycle.

Clamping the dish

When the safety door is open, the user can slide a grinding dish inside the unit, where a recess will position it. The user then closes the door, which locks.

With the door locked closed, the unit can now receive the command to start a grinding method. The unit will then check for the presence of a dish, and automatically clamp it in place.

Grinding motion

The dish will now be moved by the main motor in a horizontal circular motion. There is no rotation, as the dish remains in the same orientation while being translated about a circular path.

The circular motion of the dish is automatically counterbalanced by a mechanical system, ensuring minimal vibration transmission and noise generation.

When the grinding cycle is complete, the grinding motion slows down to a stop, the dish clamping system is released, and the safety door opens, so that the user can slide out the dish, containing the ground sample.

Using the SM-300 ShatterBox

Operation of the safety door

As mentioned above, the SM-300 ShatterBox is equipped with a semi-automatic safety door, which has a safety interlock to prevent the user from starting a grinding cycle if the door is still open.

Automatic lock operation

When the user closes the door, an electronic system will engage mechanical locks, so that the door cannot be accidentally re-opened.

Even in the case of a power failure, a mechanical lock will remain in place. When turning the unit on (or after a power failure), the door will remain up, in locked position. The display instructs the user to push the door further up to disengage the lock, so that the door can slide down freely.

Electronic unlocking

When the user has closed the door, the grinding instrument assumes that it is ready to start a grinding method and will keep the door locked.

In case the user wants to re-open the door before the grinding is started, simply press on the "Door unlock" button:



The instrument then unlocks the door, which will then automatically slide down, in an open position.

Warning: *Pinch point – keep clear of the door when it slides down.*



Manual override

When there is no power (e.g. when cleaning or packing the unit), it is possible to override the locking mechanism to manually open the safety door. Locate the lock override access hole (refer to page 6, *General view*) and use a thin tool such as a small flat screwdriver to slide the locking mechanism to the left.

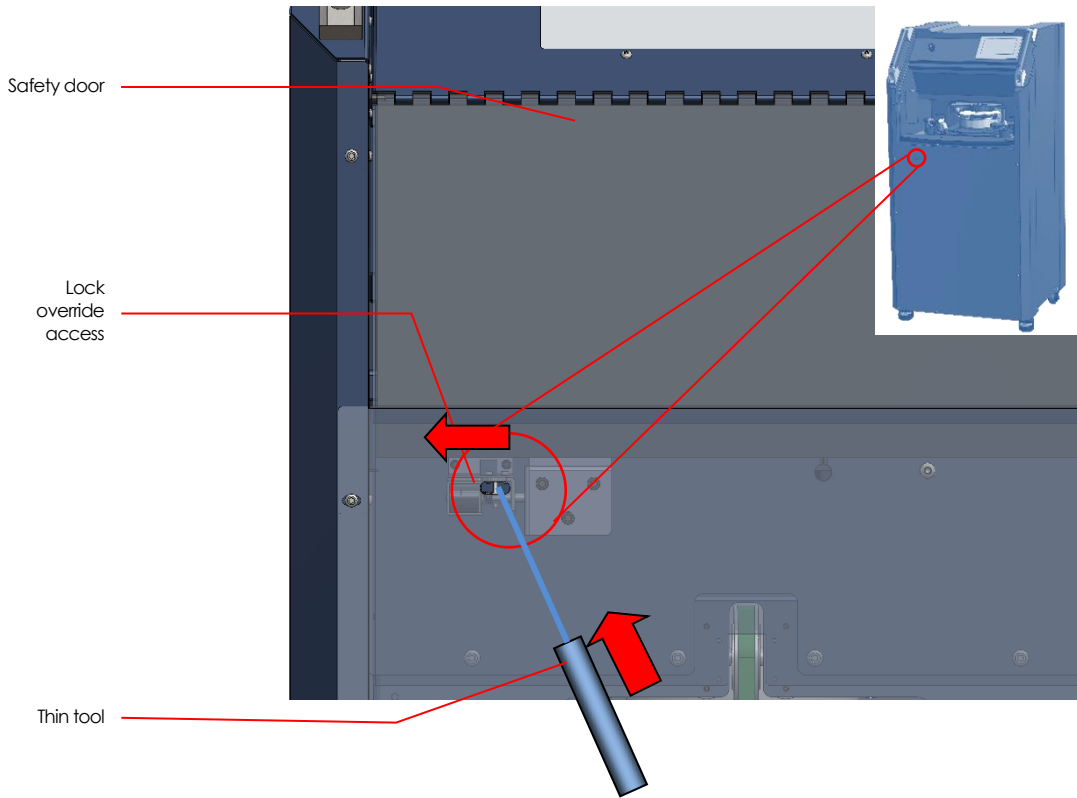

The main running screen

After the booting screen, you will obtain a display similar to the following (not all buttons/icons will appear, depending on the unit's settings):



Here is a short explanation of the various zones and buttons:



This zone offers a selection of Spex dish types, for enhanced safety and detection upon automatic clamping.

The "Any Dish" setting will work for any dish height, but it is highly recommended to select the proper type from the list. (Several custom dish heights can be set; see page 35, *Dish calibration* for details.)



These two icons indicate whether only the first grinding stage will be used (like in this example, where the second icons state is "Off"), or if stage 1 and 2 are both active.



This button allows the user to access the Special parameters screen (see page 32 for details).

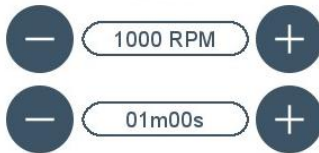

This zone is where the parameters for each grinding stage are set. The first line indicates the speed (in RPM) and the second the duration of that stage.

In this example, the unit is set to run at 1000 RPM, for 1 minutes (and zero seconds).



The "Start" button is used to launch the currently selected grinding program.

This button only appears when the dish is properly installed and the door has been closed. (The screen shows a green "Ready" line at the top.)



The "unlock shield" icon appears when the user can unlock the safety door.

The icon is not shown when the unit is actively grinding, for safety reasons.



This button is used to copy (duplicate) the current grinding program.

See page 28, *Managing grinding methods* for details.



The Delete button is used to erase a program from memory. More details are given at page 28, *Managing grinding methods*.



The Save button is used to write the current program and its parameters into memory. More details are given at page 28, *Managing grinding methods*.



This button is used to access Global parameters.

See page 30, *Global parameters* for details.



This zone is used to select the current active grinding method.

See page 24, *Loading a program* for details.



The padlock icon/button shows the state of the grinding recipe parameters.

A closed padlock means that the parameters are locked, and a password is required to unlock parameter access. Conversely, an open padlock means that all parameters can now be freely changed.

More details are given at page 27, *Programming the SM-300 ShatterBox* (advanced).

Entering the password is also required to modify the parameters of the Global parameters screen.

Loading a program

Changing the current program can be done in several ways.



- Touching the program number ("1" in the example above) will call the program selection screen.
- Touching the left or right arrows on either side of the program name will also call the program selection screen, but will also decrease/increase the program number.
- In the program selection screen, you can use the left or right arrows to scroll among the proposed programs, or you can directly select the desired program by touching its name or number.

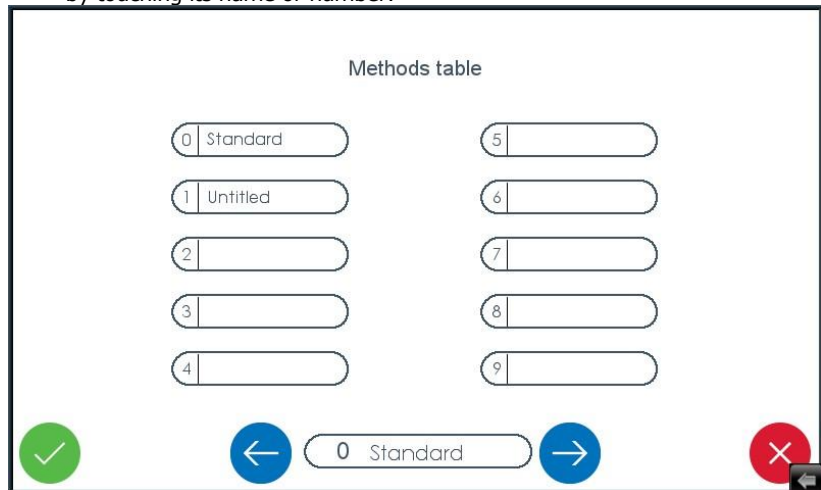

Touch the green button to confirm, or red to cancel.

During a grinding

While the instrument is running, the main screen will display additional information and buttons, as well as the number of the step currently being executed and a countdown showing the total time remaining to the grinding program.

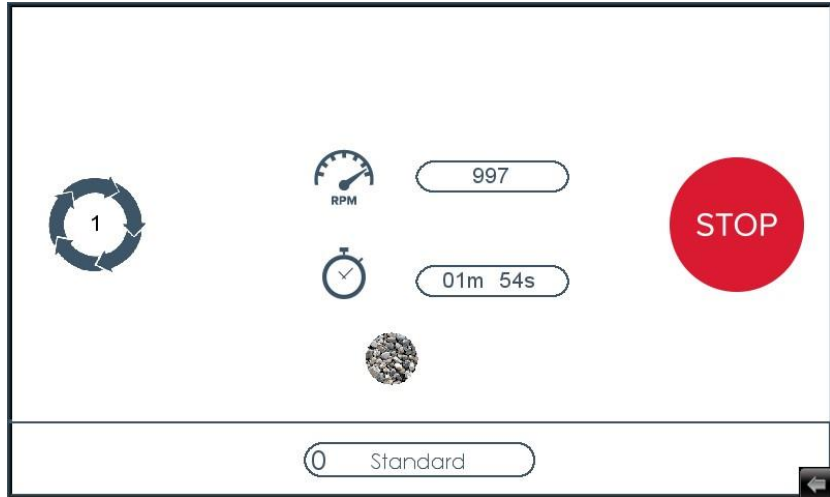

Additional graphical elements (other icons were explained on page 22, in *The main running screen* section):



01m 54s

This cluster represents the remaining time (mm : ss)



The Stop button, as the name implies, is used to halt an ongoing grinding process, stopping all motors and resetting the system.

This can be used when one realizes that the dish was not properly prepared or filled, or in case of emergency, for example.

A general grinding

Steps required to perform a grinding on the SM-300 ShatterBox:

The following sequence is typical. It supposes familiarity with the chief features of the SM-300 ShatterBox, as described earlier.

1. Switch the power on. The display will light up and the unit will perform a self-test.

2. The display instructs the user to push the safety door in a closed position. This is needed, so that internal movements of the dish locking system can be done safely.
3. The door then freely slides down in the open position, automatically.
4. Load the grinding container with sample, puck/ring and lid. Refer to page 16, *Choice of the grinding container* for more details.

WARNING: *If running the SM-300 ShatterBox without grinding any sample (e.g. for test purposes), remove the grinding element(s) from inside the container.*

5. Gently place the dish inside the unit, and slide it towards the back of the unit, until it stops, centered above a matching recess. In order for the full insertion to be possible, ensure that the handles are not hitting the anti-rotation posts.
6. Manually pull the safety door upwards, until it reaches the top and locks in place, in a closed position.
7. Select the grinding method of your choice (e.g. "Standard") on the LCD screen.
8. Press the "Start" button to launch a grinding cycle.
9. The unit will automatically lower the dish into its recess, and perform a position check using mechanical and magnetic sensors.
10. The same mechanical motion continues, and a die pushed by a screw ram presses down on the lid, until a set force is reached and the dish is securely clamped in place.
11. The SM-300 ShatterBox main grinding motor then starts and reaches the speed set for the first stage, and maintains it for the time set for said stage.
12. If a second-stage speed and time are set, the grinder switches to those at the end of the first stage.
13. Once the timers elapse, the motor slows to a stop, the dish clamping system is released and the safety door automatically opens.



Warning: *Pinch point – keep clear of the door when it slides down.*

14. Remove the dish containing your ground sample. Transfer the sample to an appropriate container, and clean the dish for the next run.

Programming the SM-300 ShatterBox (advanced)

When specific sample types do not seem to be easily processed by a preset grinding method, it is necessary to manually modify its parameters.

Unlocking the advanced mode



Before being allowed to manage grinding programs and edit parameters, one must enter the correct password. To do so, click on the padlock icon/button.



After touching the padlock button, a numeric keypad will pop up, ready for password entry.

Type the password, which is 2014.

If you make a mistake while typing, press the backspace button to clear your entry.

If you summoned the numeric keypad by error, you can close it by pressing the locking padlock icon.

Once the password is correctly typed, press on the unlocking padlock icon to confirm. The numeric keypad will close, and the padlock icon will now be displayed as unlocked.



This icon indicates that you can now modify the grinding program parameters and also manage the grinding methods (i.e. copy, delete and save). You are now in "advanced mode".

NOTE: It is not possible to modify the parameters in the preset program, and so even entering the correct password will not "unlock" the padlock icon. However, the instrument remains in "advanced mode", and so switching to a custom grinding program will "unlock the padlock" and allow parameter edition.

To close the advanced mode (i.e. "re-lock" the padlock), simply click the padlock icon and then press on the "locking padlock" icon on the keypad.

Managing grinding methods

NOTE: If you prefer to always keep the unit in "advanced mode", it is possible to do so, in the Global Parameters (refer to page 30).

Grinding methods can be managed just like files on a computer. In the main screen, you can press the icon corresponding to Copy, Delete and Save. Note, however, that the "advanced mode" must first be activated in order to perform any of the following actions.

Copying



The Copy button is useful to duplicate an existing program, to create a derived recipe. Hence, begin with a preset program that is close to the sample type you want to process, and then you will be able to fine-tune the parameters to suite your specific sample. After clicking on the icon, a window will ask for a confirmation. Click "Yes" to proceed, or "No" to cancel.

Renaming

Once a method is copied, you will be automatically brought into that copied program, named "Untitled". We suggest that you immediately rename this with some name that is relevant to your application. To rename the program, click on its name (in this case, "Untitled"), and a full keyboard will pop up. (Note that renaming a preset program is not allowed.)

Deleting



The Delete button is used to erase a program from memory. Once a program is erased, it frees the corresponding memory slot, and it cannot be recovered. Furthermore, preset programs cannot be deleted.

Saving



The Save button is used to write the current program and its parameters into memory. This icon will appear automatically when the user changes a parameter value or a setting in a program. Otherwise, the icon is not shown.

Preparing a grinding program

To build your first grinding program, you must first select the preset program template (or any existing program) that will be used as a starting point to design your own program. In most cases, the Standard program is a good all-around program. Copy it under your desired name, as described above.

Once this "editable" program exists, you can adjust parameters to suit your sample.

Grinding steps



Grinding methods all have the same simple structure, having up to two steps (or stages), each featuring two parameters: Speed and Duration.



Many sample types actually require only one grinding step.

If you need only one grinding step, you can touch the icon of the second step, to toggle it from active (with green arrows all around) to inactive (Off, with red arrows all around.)

Speed



The grinding speed (i.e. the rotation speed of the motor, measured in RPM) can be adjusted by pressing on the plus and minus buttons besides the speedometer icon.

Note : *The SM-300 ShatterBox firmware prevents the unit from going above certain speed limits, to prevent damage to specific dish types. To ensure using the whole range of permissible speeds for your specific dish, make sure to select the appropriate dish type in the Special Parameters (see page 32).*

Duration



Step duration (mm : ss) is also adjusted by pressing on the plus and minus buttons. For each step, the duration parameter is limited to 19 minutes and 55 seconds.

Global parameters

In addition to recipe-specific parameters, your mill provides extra versatility through flexible parameters that will apply to all grinding programs.



To modify the global parameters, first unlock the advanced mode (see page 27, *Unlocking the advanced mode*), then touch the Global Parameters icon that is now available on the main display screen.

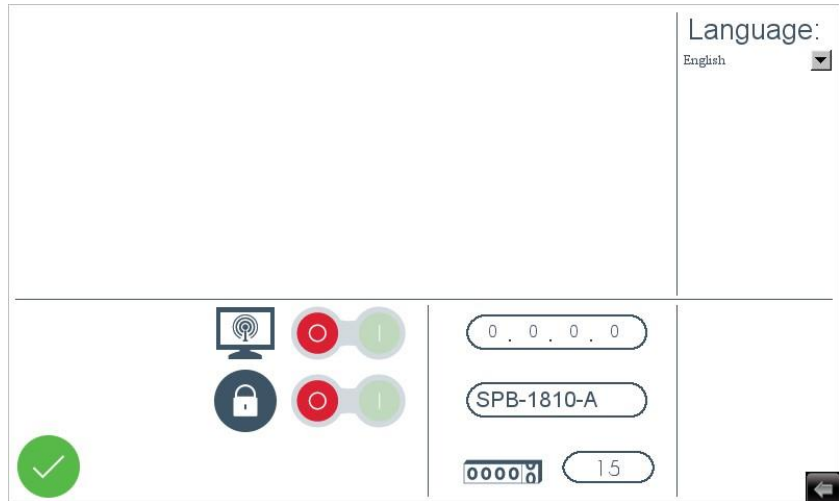

Options

Language:
English

This section allows you to pick from a selection of available interface languages.



Turning On this switch allows for the remote control and diagnostics of the ShatterBox over a wired network.



This box shows the IP address of the ShatterBox, when successfully connected to a wired LAN network.



Turning Off this switch will initialize the unit in Advanced mode at boot up, so that password entry is not needed anymore. If the password is changed or deleted with the padlock icon/button, the Advanced mode will be disabled until next boot up or until it is manually entered again.

SPB-1810-A

This box shows the serial number of the ShatterBox unit.

0000%

15

The number to the right of the "odometer" icon shows the total number of grinding cycles that the ShatterBox unit has performed.

Special parameters

This section presents an advanced interface window that can be used to adjust the sensitivities and offsets of various sensors on the mill.

WARNING: Changing these parameters should only be done by trained personnel. Incorrectly setting these parameters could cause damage to the unit.

Accessing the Special parameters



To invoke the Special parameters window, Press on the “Special Parameters” icon shown here, located between the Grinding stage Icons of the main screen.

(The padlock icon must be in unlocked position to see the “Special Parameter” icon that will allow to reach this screen. See *Unlocking the advanced mode* on page 27 for details.)

The following window appears:

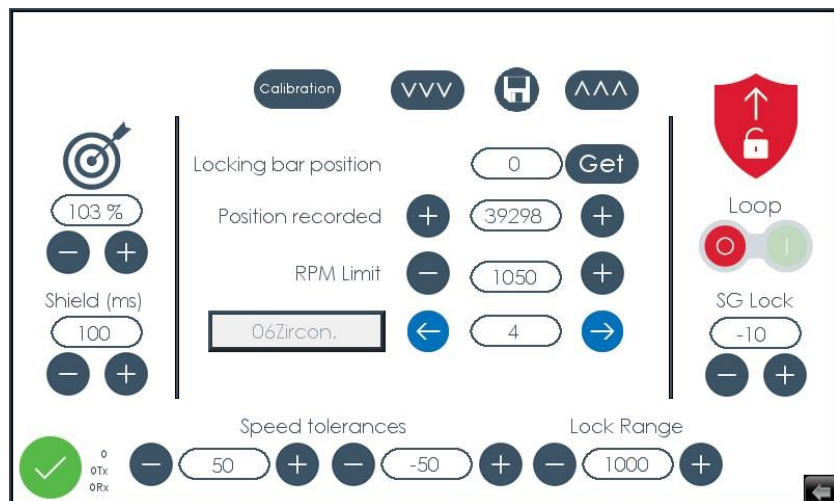

Parameters description



This parameter controls the calibration of the motor speed drive.

This has been factory-set and should not be changed unless advised by a Cole-Parmer service technician.



This parameter controls the delay for the opening of the shield.

This has been factory-set and should not be changed unless advised by a Cole-Parmer service technician.



This button starts an automatic calibration of the locking bar position for a grinding dish.

Refer to next section for details.



This is used for manual calibrations, or for debugging purposes.

The arrows are used to press or release the dish.

The diskette icon is used for saving the current clamping position.



This button is used to read the current locking bar position and show the value in the "Position recorded" field. Once modified, one will need to press the diskette icon to store the new value.



This section is used to show the current recorded position of the locking bar.

Increase / decrease allow to manually fine tune the recorded position if needed. Once modified, one will need to press diskette icon to store the new value.

RPM Limit  1050 

This section is used to set the maximum allowed motor speed for a given dish.

Tungsten carbide and large hardened steel dishes should always be limited to 1050. If you create a new calibration for those, make sure the RPM limit is limited to 1050. All other dishes can go up to 1200 RPM.

  4 

This is used to scroll among existing calibrated dish entries.

Speed tolerances

 50   -50 

This is used to set the allowed grinding speed deviations, before an error is thrown.

This has been factory-set and should not be changed unless advised by a Cole-Parmer service technician.

Lock Range

 1000 

This section sets the number of motor steps to confirm the dish is locked.

This has been factory-set and should not be changed unless advised by a Cole-Parmer service technician.

Loop



This switch is used to put the instrument in continuous loop. After a cycle is completed, as soon as the door is re-closed, a new cycle will start without needing to press Start button. As soon as Stop is pressed, the Loop switch turns back Off.

SG Lock

This section sets the lock sensibility parameter for the locking of the dish.

This has been factory-set and should not be changed unless advised by a Cole-Parmer service technician.

Dish calibration procedure

If you have a dish whose height is not within the standards that existed when the grinder was manufactured, you can create a new entry for your custom dish. The same procedure can be done if frequent locking errors appear, due to parts compression/wear.

1. With the grinder turned on, insert the desired dish in the grinding location.
2. Slide the door up until it locks.
3. In the *Special parameters* screen, use the left/right arrows to navigate to the dish that you wish to re-calibrate.
4. With the arrows beside the dish name, select the dish number for which you want to update the calibration or select an unused calibration number to create one.
5. If desired, modify the name of the dish to your preferred one by pressing on it. A keyboard will appear to allow you to enter one. (The default name "Any Dish" at index 0 cannot be modified.)
6. Press on "Calibration" and let the system start a series of clamp/unclamp operations and determine the best settings, which will become the new norm for the selected dish name. After the process completes entirely, the calculated position will be recorded automatically.

You can interrupt the process at any time by pressing the X button of the status window. In such case, the calculated locking position up to now will **not** be recorded automatically. If you want to keep this value, press the save (diskette) icon.
7. Press the green button to exit this screen and start a test grinding run.

Grinding troubleshooting

This section presents the most common grinding-related problems. For specific assistance, please do not hesitate to contact us (see page 50, *Contact*).

Unit does not turn on

No power at all

Make sure power cord is plugged into outlet.

Check outlet for power and correct voltage as required.

Blown fuse

Replace fuses.

Power switch not turned on

Press power switch to ON position.

Unit does not run

Safety interlock switch

Make sure the door is completely closed. Adjust latch if necessary

Door remains locked

Wait 5 seconds before lifting lid.

Lid latch jammed.

Grinding container locked up, won't grind

Too much sample is in the vial or sample pieces are too large.

Reduce sample quantity or size of sample pieces.

**Excessive
vibration, unit
“walks”**

Casters not locked.

Lock casters.

Locking failed

Grinding container is not well inserted. Make sure you slide it completely to the back.

Locking height calibration is wrong or wrong dish is selected in the method. Please refer to *Dish calibration procedure* section to redo dish calibration.

Periodic inspection

This instrument requires some regular checking, which is very important to keep your instrument up and running.

Cole-Parmer knows that a broken instrument in a laboratory setting causes sample back-up and unnecessary costs. That is why this manual comprises not only a Periodic inspection section, but also a Service operations chapter (see page 39), which guides the user in a step-by-step fashion through operations that sometimes need to be performed on-site.

If unsure, do not hesitate to get in touch with a Cole-Parmer technician (see page 50, *Contact*). Assistance by phone or email is always free of charge.

Note that no modifications of the instrument are allowed, except those explicitly described and permitted in this manual. Any undue modification automatically cancels the warranty and could endanger the user's life.

Warning



Inspection schedule table

IMPORTANT: *Some of the procedures described in the following pages imply a risk of death by electrocution; those procedures shall be executed only by trained personnel.*

Frequency	Checkpoint	Description	Action (if problem found)
1 month or 300 cycles	Clean dish table	Use a vacuum cleaner to remove any visible dust from the area where the dish sits and slides into the unit.	
	Visual inspection for wear	Check for wear of plastic parts (40487 and 40492) around the dish seat. Check for wear of rubber inserts (40491) under the dish. Check for wear of rubber inserts (40493) in the locking bar.	Replace parts as needed
6 months or 2000 cycles	Complete clean-up	Remove back panel and use a vacuum cleaner to remove any visible dust from the inside of the unit.	
	Motor link inspection	Remove back panel and check elastic bands for wear, signs of aging or loss of tension.	Replace rubber bands

Service operations

This section describes tasks that are performed on a regular basis, and are performed to adjust or repair a malfunctioning system of the instrument.

Some sections also describe initial operations, which need to be performed before first using the unit.

Should you have any question, or need further assistance, please do not hesitate to contact us (see page 50, *Contact*).

Warning



IMPORTANT: *Some of the procedures described in the following pages imply a risk of death by electrocution; those procedures shall be executed only by trained personnel. 240 Volts inside !*

Top panel removal



In order to gain access to most electronic components, it is necessary to remove the top panel.

IMPORTANT: Always disconnect the instrument from the power outlet when working with panels removed. 240 Volts inside! Risk of electrocution!

1. Disconnect the instrument from the wall outlet.
2. Remove the screws as shown on the picture below.

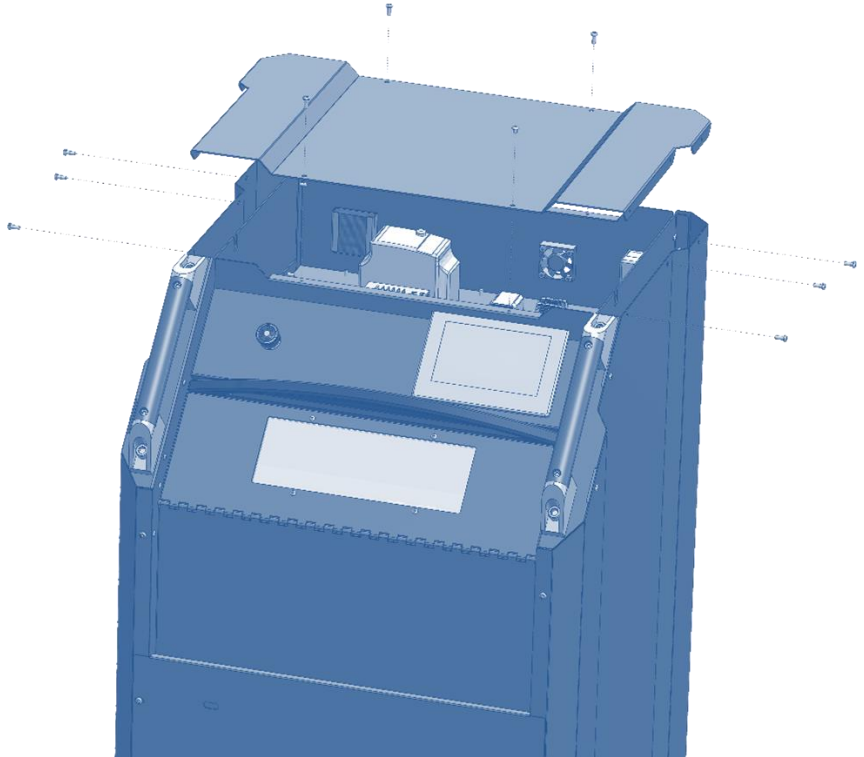

Front panel removal

In order to gain access to the door mechanism and sensors, it is necessary to remove the front panel.



IMPORTANT: Always disconnect the instrument from the power outlet when working with panels removed. 240 Volts inside! Risk of electrocution!

1. Disconnect the instrument from the wall outlet.
2. Remove the screws as shown on the picture below.



Door removal

The following procedure describes how to remove the sliding door. This may be necessary to resolve door operating issues (e.g. adjust the height of the locking solenoid, access the safety switch...)



IMPORTANT: Always disconnect the instrument from the power outlet when working with panels removed. 240 Volts inside! Risk of electrocution!

1. Disconnect the instrument from the wall outlet.
2. Remove the Front panel of the unit (see previous section).
3. Remove the screws that fasten the door handle.

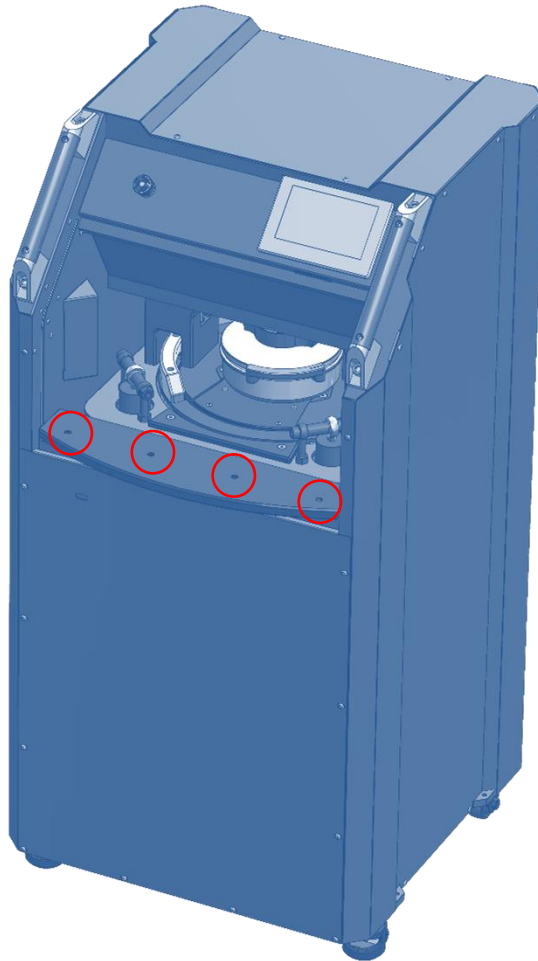

4. Remove the screws from the two bumper brackets and the counterweight bracket.

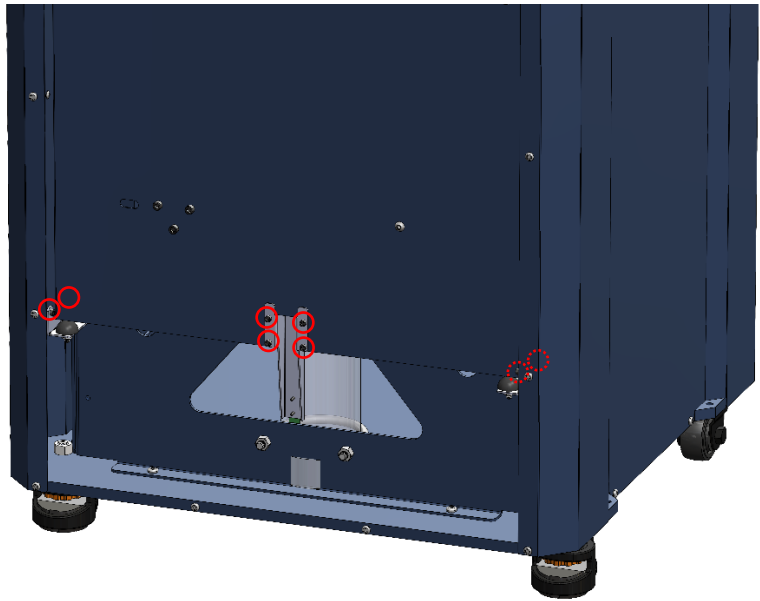

5. Hold the door up, while pulling the counterweight bracket down, to disengage it. (**WARNING:** Door is heavy!)

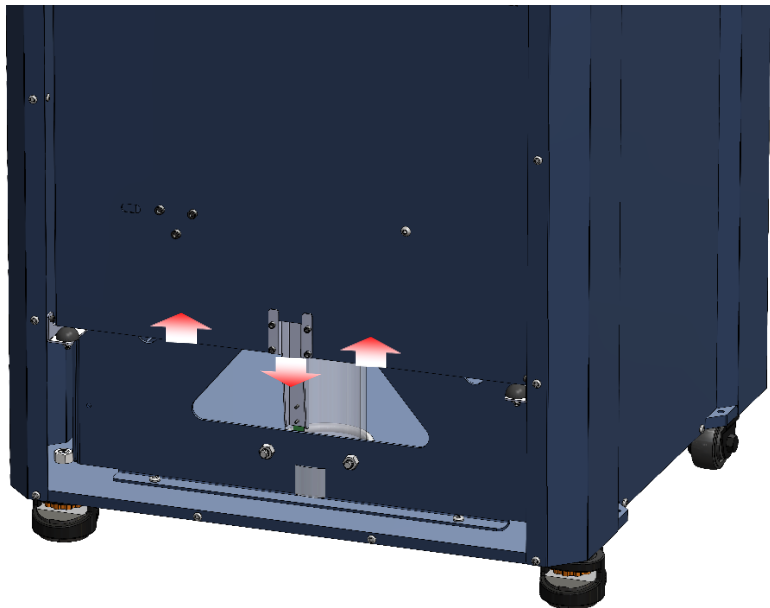

6. Gently let the door slide down and pull it off its guide rails.

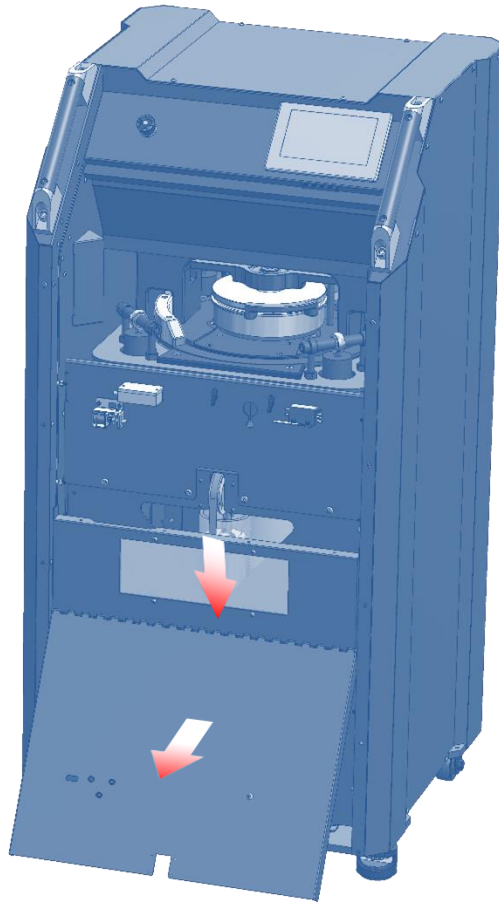

Back panel removal

In order to gain access to the flexible motor link, it is necessary to remove the back panel.



IMPORTANT: Always disconnect the instrument from the power outlet when working with panels removed. 240 Volts inside! Risk of electrocution! Never operate the instrument with the back panel removed

1. Disconnect the instrument from the wall outlet.
2. Remove the screws as shown on the picture below.

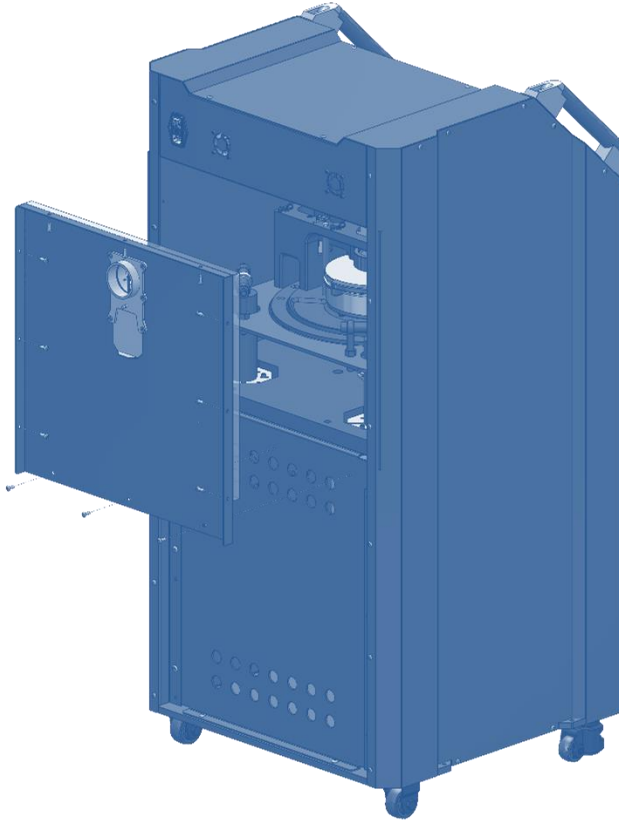

Firmware and program transfers

Preset programs

This section lists the methods that are factory programmed into the SM-300 ShatterBox. It is not possible for the user to alter or delete them.

Note that Cole-Parmer cannot be held responsible for any damage to dish or mill incurred by the use of those methods. If unsure, please contact Cole-Parmer. We will be glad to prepare an adapted method for your specific sample.

Number	Name	Description
0	Template	Reference method for the creation of customized method

Backup or restore by USB

Once your favorite methods are developed and optimized, you might want to store them on a USB flash drive, especially before upgrading the firmware of your instrument. This can also be useful to transfer grinding programs among several grinding instruments.

Alternatively, you might have received from Cole-Parmer a firmware upgrade that you want to install on your instrument.

Backup mill to USB drive

1. To start the process, simply insert a USB flash drive into the USB port of the grinding machine. A dialog will automatically pop up, after a few seconds.
2. Touch "Upload".
3. A dialog will appear, requesting a password and what data to upload. The password is "111111" (six times the digit one). You may have to drag the dialog window to the left, to show the keyboard and then type the password.
4. Select "Upload Project Files" if you want to back up the firmware (i.e. the instrument's operating system).
5. Select "Upload History Files" if you want to back up the grinding programs' parameters.
6. Touch "OK".

7. Now, choose where you want the data to be written. Double-click on "USBDISK", then click on its sub-directory, named "disk_a_1".
8. Click "OK" to start the transfer to the USB drive. The screen will black out, and the mill will re-boot.
9. The firmware or the programs are now saved, and you can remove the USB drive.

Restore programs, firmware or upgrade firmware

1. If you want to restore a backup that you have made yourself, simply insert the USB drive that contains you backup files, into the USB port of the mill.
2. If you have obtained a new firmware by email, extract the directory structure and files you have received in the root directory of a blank USB drive. Then, insert the USB drive into the instrument's USB port.
3. A dialog will automatically pop up, after a few seconds.
4. Touch "Download".
5. A dialog will appear, requesting a password and what data to download. The password is "111111" (six times the digit one). You may have to drag the dialog window to the left, to show the keyboard and then type the password.
6. Select "Download Project Files" if you want to restore or upgrade the firmware (i.e. the instrument's operating system).
7. Select "Download History Files" if you want to restore the grinding programs' parameters. *Note that this will erase ALL grinding programs currently stored on your mill.*
8. Touch "OK".
9. Now, choose where you want the data to be fetched. By default, you will have to double-click on "USBDISK", then click on its sub-directory, named "disk_a_1". If the data was created in another (sub-) directory, you will need to browse to reach it.
10. Click "OK" to start the transfer to the USB drive. The screen will black out, and the mill will re-boot.
11. The new firmware or programs are loaded, and you can remove the USB drive.

Technical specifications

Type of mill:	Grinding Mill
Grinding mechanism:	Grinding containers with puck and ring
Weight (without grinding container):	200 kg (440 lbs)
Dimensions (w x d x h):	67.5 x 66 x 138 cm (26.6 x 26 x 54.3 in)
Electrical:	115 V / 60 Hz (10-amp fuse) or 230 V / 50~60 Hz (10-amp fuse)

NOTE: Operator is responsible for supplying proper line cord/plug if required. Contact an electrical if unsure.

Fuses:	115V version: 10-amp fast-blow fuse in inlet module or 230V version: 10-amp fast-blow fuse in inlet module
---------------	--

Motor:	1/2 HP, 1800 RPM
Operating conditions:	indoors, in ambient air
Ambient temperature:	4~35°C (40~90°F)
Humidity:	0~95%

Warranty

Cole-Parmer® guarantees its products against defects in materials or workmanship for three years from the date of original shipment. Repairs, replacements, or parts are guaranteed for 30 days or for the remaining original warranty period (whichever is greater) for the item that was repaired or replaced. Items not produced by Cole-Parmer® carry the manufacturer's warranty only.

The warranty excludes wear parts. These are parts that wear out through use and must be replaced periodically for proper operation. SM-300 Shatterbox wear parts include the following which can be changed by the user.

In the event that these or other parts require service, please contact Cole-Parmer to arrange a return shipment.

The customer pays return freight for warranty claims. If the warranty claim is valid, Cole-Parmer® will pay return freight to the customer. However, Cole-Parmer® reserves the right to judge whether a malfunction during the warranty period is due to defects in materials or workmanship, or to wear, negligence, or misuse.

Product changes

Every effort has been made to provide complete and accurate product operation and information in this manual. However, since specifications are subject to change without notice, changes may be made from time to time to improve the performance of the product.

Return shipments

We want you to be satisfied with your purchase from Cole-Parmer®. Please bring any problem to our attention, but please DO NOT RETURN any item before contacting us for a Return Authorization Number and instructions. Unauthorized returns will be refused. The cost for all return transportation is the responsibility of the customer. Credit for returned merchandise will be issued only after goods have been received and inspected. Returned goods are subject to a 25% restocking charge.

Contact US

Repair Service

Phone: 1.732.623.0465

Cole-Parmer
65 Liberty St
Metuchen, NJ 08840
US

Attn: Service and Repair
Please include RA Number on the shipping label.

Cole-Parmer®

an Antylia scientific company

625 East Bunker Ct.
Vernon Hills, IL 60061
US

US

T: +1.800.323.4340 or
+1.800.323.4340

E: sales@antylia.com

W: coleparmer.com

Canada

T: +1.514.355.6100

E: info@antylia.ca

W: coleparmer.ca

China

T: 86.21.5109.9909

E: sales@antylia.com

W: coleparmer.cn

France

T: +33 (0) 1486 37800

E: fr.sales@antylia.com

W: coleparmer.fr

Germany

T: +49 (0) 9377 92030

E: de.sales@antylia.com

W: coleparmer.de

India

T: +9122 61394444

E: info@coleparmer.in

W: coleparmer.in

Italy

T: +39 (0)2 84349215

E: it.sales@antylia.com

W: coleparmer.it

UK

T: +44 (0) 1480 272279

E: uk.sales@antylia.com

W: coleparmer.co.uk

Other

T: +1.847.549.7600