

Cole-Parmer®

CG-500 Freezer/Mill®

Cryogenic Grinder Designed for Milling Tough and Temperature Sensitive Samples

Operation Manual

For 115V (04500-42) and 230V (04577-94)



For Product Information



Copyright 2023 by Cole-Parmer®

All rights reserved. No part of the work may be reproduced or transmitted in any form or by any means, electronic or mechanical; including photocopying and recording, except as may be expressly permitted by the 1976 Copyright Act or in writing from the publisher. Requests for permission should be addressed in writing to Cole-Parmer®, 65 Liberty Street, Metuchen, NJ 08840.

SPEX SamplePrep is now part of Cole-Parmer®.

The Cole-Parmer® CG-500 Freezer/Mill was formerly known as SPEX 6875D Freezer/Mill.

Over the years, we've acquired many high-quality and reputable brands. After many years of continual growth, we realize our brands are all as brilliant as each other. Rather than have a portfolio of complementary brands, we felt consolidating them under one world-class brand name enabled us to offer a single and significant brand experience. Through one brand we can speak in one voice through our team of experts who provide support in product selection, usage and troubleshooting to empower laboratories to run efficiently throughout the world.

Same Great Quality!

One World-Class Brand Name!

TABLE OF CONTENTS

SECTION	DESCRIPTION	PAGE
1.0	Introduction	4
2.0	Specifications	5
3.0	Unpacking	6
4.0	Setting Up	7
4.1	Electrical Connection	7
4.2	Power Switch and Controller	8
4.3	Liquid Nitrogen Connection.....	9
4.4	Lid, Coil Assembly and Gate, LN Sensor	10
4.5	Grinding Vial Sizes, Adapters, and Vial Openers.....	11
5.0	Touchscreen Display	12
5.1	Logo Screen.....	12
5.2	Control Panel.....	13
5.3	Changing Settings.....	17
5.4	Saved Protocols.....	18
6.0	Operation	20
6.1	Standard Auto Fill.....	20
6.2	Manually Adding Liquid Nitrogen.....	21
6.3	Loading Vials into the Freezer/Mill.....	24
6.4	Removing Vials from the Freezer/Mill.....	24
6.5	Opening, Emptying, and Cleaning Freezer/Mill Vials.....	24
6.6	Checking the Liquid Nitrogen Level	27
7.0	Run History	27
8.0	System Settings	28
9.0	Maintenance	28
10.0	Trouble-Shooting Guide	29
11.0	Warranty	31
11.1	Product Specifications	31
11.2	To Arrange a Return Shipment	31
12.0	Instrument Disposal	32
13.0	Contact Us	33

1.0 INTRODUCTION

Cole-Parmer Freezer/Mills are laboratory mills that cool unconventional materials to cryogenic temperatures and pulverize them to a powder form without thermal degradation. Our proven technology uses a dual electromagnetic, grinding chamber that rapidly drives a steel impactor back and forth against the two end plugs of the sample vial. Since the vial is securely closed the integrity of its contents is maintained, hazardous or critical samples are easily controlled, and cross-sample contamination is eliminated. The sample chemical composition is preserved as a result of the vials being immersed in liquid nitrogen at cryogenic temperatures throughout the grinding process. The CG-500 Freezer/Mill expands on this technology utilizing dual grinding chambers and two additional precooling chambers for increased sample throughput. The CG-500 Freezer/Mill has been re-engineered with a liquid nitrogen Auto Fill feature which comes standard in every unit. The preference to Manual Fill the unit with liquid nitrogen is optional. These unique aspects have made Cole-Parmer Freezer/Mills the most effective cryogenic mills in the world. They are the “mills of first choice” for many abnormal materials, or samples whose composition or structure cannot be ground using conventional grinding methods.

NOTE: Do not operate the CG-500 Freezer/Mill until you have read the Operating Manual and are familiar with the controls and operation.

OPERATING CONDITIONS: Do not set up the CG-500 Freezer/Mill in an insulated or confined space. The Freezer/Mill should be run on an open countertop, in ambient air, with recommended maximum relative room humidity 70% from 5°C - 31°C (40°F - 88°F). If the entire mill is chilled during operation, components such as the gas springs, controller, and display screen can fail. This damage is not covered by the Freezer/Mill warranty. During operation, water vapor in the air will condense on parts of the unit. For this reason, it is important not to place any moisture-sensitive equipment near the Freezer/Mill.

VERY IMPORTANT: Liquid nitrogen(LN) not only makes samples brittle through severe chilling and making them “grindable,” but it also cools the magnetic coils which power the CG-500 Freezer/Mill. If the unit is operated in the optional Manual Fill mode the liquid nitrogen level should be visually checked during extended runs as well as topped off before every run. Operating the unit without liquid nitrogen for a period of one minute will cause the coils to become very hot and may sustain permanent damage. The CG-500 Freezer/Mill has an LN sensor that will shut down the unit when the liquid nitrogen gets too low to cool the coils. The Freezer/Mill warranty does not cover damage to the coils caused by operating the mill with little or no liquid nitrogen. We recommend operating the unit in Auto Fill mode with LN Tank.

SAFETY: Liquid nitrogen (LN) can be hazardous. Its boiling point is -195.8°C (-320.4°F). When working with liquid nitrogen directly or indirectly, the LN Tank valve or hose, or chilled Freezer/Mill components, cryogenic gloves must be worn to protect hands. A face Shield is also recommended to protect eyes from possible splashing. Wear the proper protection equipment PPE).

2.0 CG-500 FREEZER/MILL SPECIFICATIONS

Type of Mill: Dual Chamber Cryogenic impact mill
Controller: Touchscreen
Data Transfer: Dual USB Port (back of controller)
Grinding Mechanism: Steel impactor driven by magnetic coil
Coolant: Liquid nitrogen (LN)
Dimensions: 20 in. (50.8 cm) x 21½ in. (55 cm) x 25½ in. (64.77 cm)
Weight: (empty, without vial or coolant) approx. 78 lbs. (35.38 Kg)
Grinding Vials: One Large Vial (6801, 6803, 6871), one Mid-Size Vial (6881, 6883, 6885), one to four Small Vials (6751, 6761, 6771, 6781S) or one to four Microvial set (6757). (Per Chamber)

Typical Vial Capacity: ***Small Vial:*** actual volume with impactor, approx. 25 ml. Typical sample weights: 2 grams for biological samples, 1 gram for polymers.
Microvial Set: 100 - 500 mg per individual Microvial, depending on sample.
Mid-Size Vial: up to 5 times the sample capacity of Small Vial.
Large Vial: Approximately twice the sample capacity of Mid-Size Vial, or up to 10 times that of Small Vial.
Actual performance of any vial/sample combination depends on sample properties, cooling time, grinding time, desired outcome, etc. Effective capacity for a given sample is determined by experiment. Overfilling a vial greatly reduces its efficiency.

Typical Liquid Nitrogen Consumption: 15-19 liters for initial cool-down and filling of the tub.
4-6 liters for each hour of operation. Actual liquid nitrogen consumption can vary. A minimum 200L LN Tank is recommended.

Electrical Specifications: CE Approved. Available as 115V/60HZ or 230/50HZ.

Circuit Breaker: Same as ON/OFF Switch.

Power Cord: 115V/60HZ version: 3-prong grounded plug supplied.
230V/50HZ version: 2-prong European plug supplied.
Operator is responsible for supplying alternate line cord/plug.

Safety Features: Lid Interlock prevents mill from running if lid is not securely latched.
Liquid nitrogen sensor shuts down the mill if LN level is too low.

NOTE: *The liquid nitrogen sensor can shut down the mill during a run if LN level is low. The Freezer/Mill warranty does not cover damage to the magnetic coils caused by operating the mill with little or no liquid nitrogen.*

3.0 UNPACKING

Inspect the exterior of the packing box and report any visible damage to the carrier. Remove all packing documents from the exterior of the box, and save them for your records. Open the top of the shipping box. Remove the packing material and accessories, and gently remove the CG-500 Freezer/Mill. Visually check the mill for any damage that may have occurred during shipping. Unlatch the lid and inspect the interior of the tub, ensuring that it is free of any packing material. Check the packing list to see that there are no parts missing, and inspect the accessories. We recommend storing the packaging materials in the event there is a need to return the unit for warranty service or repairs.

Grinding vials must be purchased separately and are available in four sizes: large, mid-size, small, and micro. An Accessory Package is available to match your choice of vials for each new CG-500 Freezer/Mill. The 6870L for large vials, the 6870M for mid-size vials, the 6870S for small vials or 6757 for microvials. The 6870S also includes a vial holder for running up to four small vials per CG-500 grinding chamber. The full range of grinding vials and accessories for the CG-500 Freezer/Mill is described in our catalog, The Freezer/Mill Accessory Manual, and at www.Cole-Parmer.com.

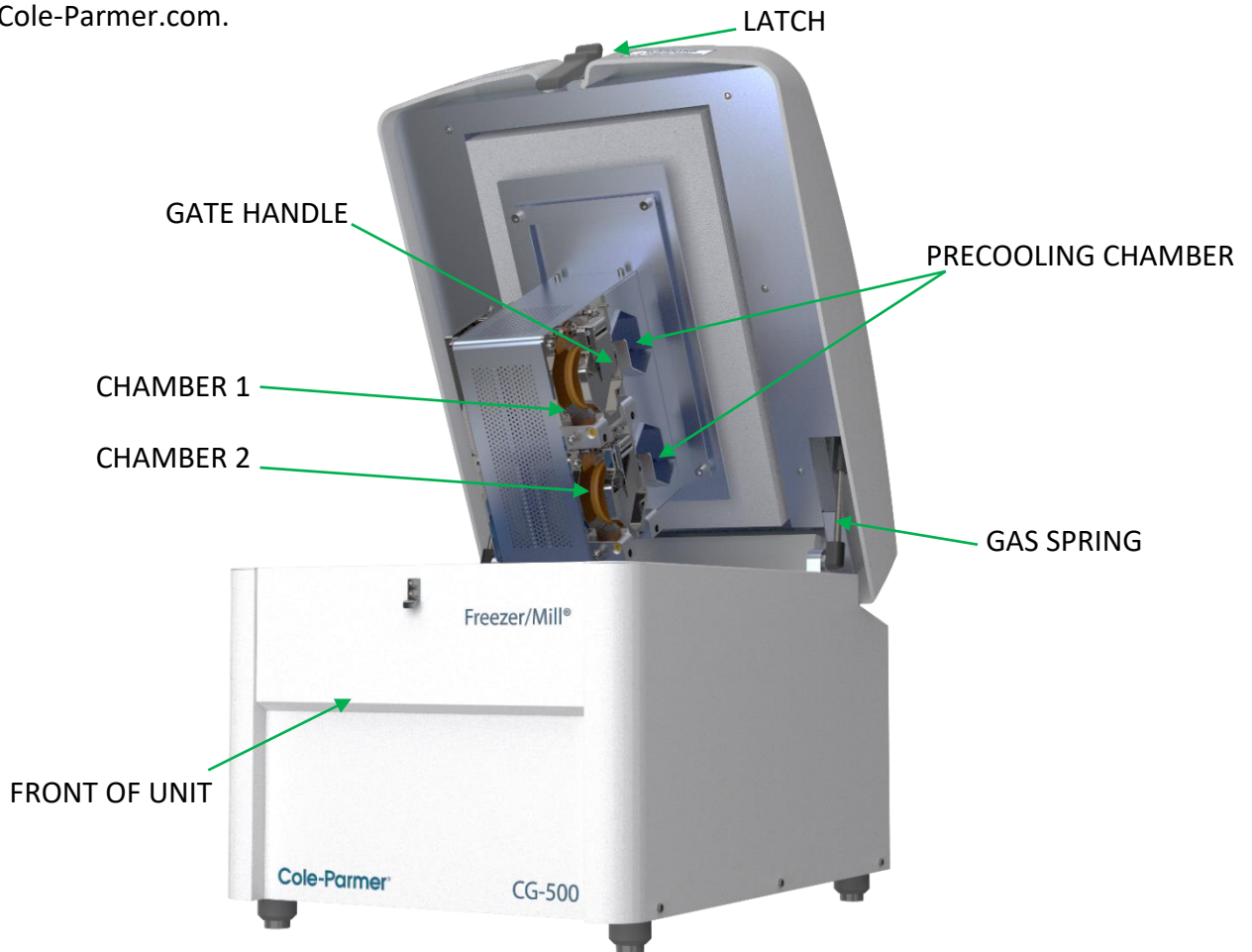

Figure 1 – CG-500 Freezer/Mill, Front View

3.0 UNPACKING (Cont'd)

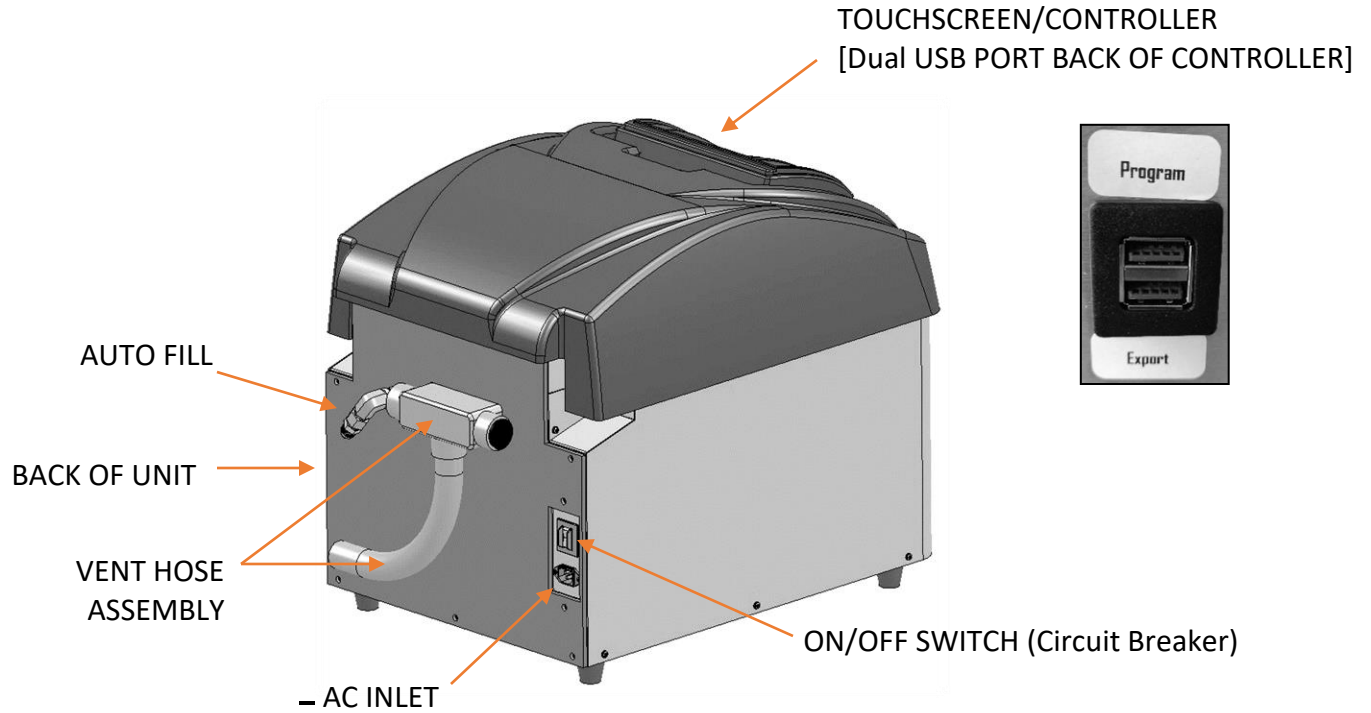

Figure 2 – CG-500 Freezer/Mill, Rear View

4.0 SETTING UP

The CG-500 Freezer/Mill weighs 78 pounds (35.38 Kg) empty. The lid opens from the front with the lid latch in the center. The AC Input module and the ON/OFF switch (which also serves as a circuit breaker) are on the back of the cabinet. The vent for the liquid nitrogen tub is on the back of the cabinet where the vent hose assembly is attached. There are gas springs on both sides of the cabinet to control the movement of the lid. The touchscreen, controller is affixed to the top of the lid and linked to the unit by a RJ45 Ethernet cable connector. At the back of the controller is a “dual” USB Port to download run data, or to upgrade software.

Caution:



Do not tip the Freezer/Mill on its side to drain liquid nitrogen out of the tub. Damage can occur to the mill preventing it from operating. In a well vented room, raise the lid to its full upright position and allow the liquid nitrogen to evaporate.

4.1 Electrical Connection

Plug the electrical cord into the AC Inlet on the back of the Freezer/Mill cabinet, and then into a standard 3-prong grounded electrical outlet. The 230V/50HZ CG-500 Freezer/Mill is supplied with a standard European 2-prong plug with cord. For the 230V/50HZ version, make sure the cord and plug conform to local electrical codes.

4.2 Power Switch and Controller

Electric power to the Freezer/Mill is controlled by a rocker switch on the inlet module. It is marked with two numerical symbols (0 for OFF and 1 for ON). Press the “1” side of the switch to turn the power ON, or press the “0” side of the switch to turn the power OFF. When power to the mill is turned ON, the controller display will light up followed by a beep.

The controller is a touchscreen that can be activated by a fingertip or stylus. Run data is transferred to other computer devices via USB Port, located in back of the controller. The CG-500 Freezer/Mill can be programmed to operate Chamber 1 only, or Chamber 1 and Chamber 2 simultaneously through the control panel by successive screens which are described and illustrated in Section 5.2. The programmable parameters include Cycles (number of grinding periods), Precool Time (initial chilling of sample), Run Time (grinding period), Cool Time (time between grinding periods), and Rate (speed of the impactor in cycles per second). The control panel also displays a warning if the lid is not fully closed, or if there is not enough liquid nitrogen in the tub.

The viewing angle of the controller on the CG-500 Freezer/Mill can be adjusted to minimize glare. To adjust the viewing angle, simply grasp the back of the controller box and gently pull it forward until the desired angle is reached, as shown in Figure 3. If it is necessary to send the unit back to COLE-PARMER for service, be sure to return the controller to its horizontal position before packing the unit for shipping.

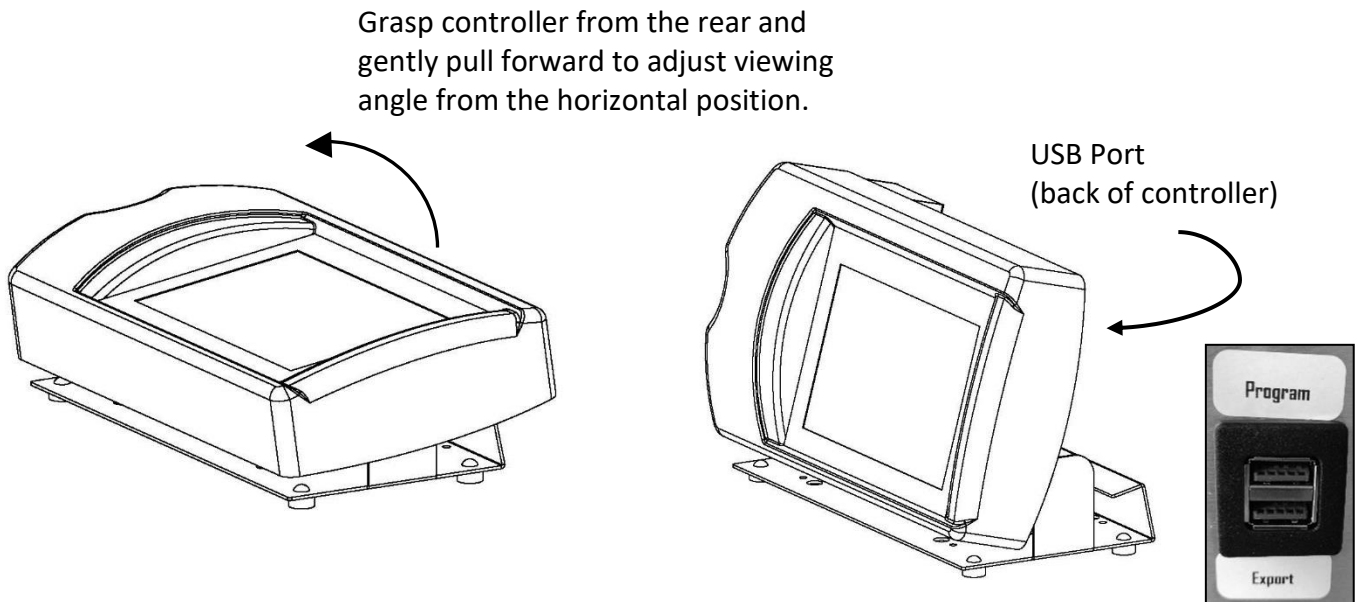

Figure 3 – Adjust the Viewing Angle of the Controller

4.3 Liquid Nitrogen Connection

The CG-500 Freezer/Mill was re-engineered with an Auto Fill feature that comes standard with every unit. The Auto Fill transfers liquid nitrogen to the tub during operation, making hand-filling the LN tub optional. The Auto Fill mechanism includes a cryogenic valve linked to LN sensors in the tub. When the LN Level is Low, the valve opens during Precool or Re-Cool stages to let liquid nitrogen into the tub. The liquid nitrogen connection, as supplied also includes a safety valve for the liquid nitrogen transfer hose.

Liquid nitrogen transfer hoses can vary with LN Tanks or LN lines and is therefore not included with the Liquid Nitrogen Connection. Four-foot and six-foot transfer hoses of standard design (part numbers 6906 and 6907) can be purchased separately from Cole-Parmer, or custom transfer hoses can be designed specifically for the user. The liquid nitrogen inlet is a male 1/2 inch JIC fitting placed low on the right (facing) side of the Freezer/Mill, the outlet of the hose requires a female CGA295 fitting. The 160 liter and 240 liter LN Tanks used by many of our customers typically have a male 3/8 inch (9.5 mm) NPT outlet, COLE-PARMER transfer hoses come with a matching female 3/8 inch NPT fitting. Excessively long transfer hoses are not recommended.

LN Tanks come in two types, high-pressure and low-pressure. Some LN Tanks have valve systems to switch from low pressure to high pressure. **Always use a low-pressure liquid nitrogen supply, with a delivery pressure of 20-22 psi.**

Install the safety valve on the outlet of the LN Tank or LN line, with the gooseneck tilted up and the valve outlet down (Figure 4). Then attach the LN transfer hose to the safety valve, and the other end to the inlet on the CG-500 Freezer/Mill. The safety valve should be higher than the LN inlet on the Freezer/Mill. The purpose of the safety valve is to provide an exit for liquid nitrogen vapor in case the mill and LN Tank valves are both closed, and pressure builds up inside the hose. ***Caution: When the lid is closed and latched, nitrogen vapor which vents from the Freezer/Mill can displace the oxygen in a closed room and cause asphyxiation.***

When installing the safety valve and transfer hose, use Teflon plumber's tape on all threaded fittings, and tighten the nuts with a wrench. If the fittings leak, tighten them further and/or use more Teflon plumber's tape.

Caution: Safety goggles should be worn at all times to protect eyes from accidental splashes or liquid nitrogen vapor. Cryogenic gloves must be worn to protect hands.

4.3 Liquid Nitrogen Connection (Cont'd)

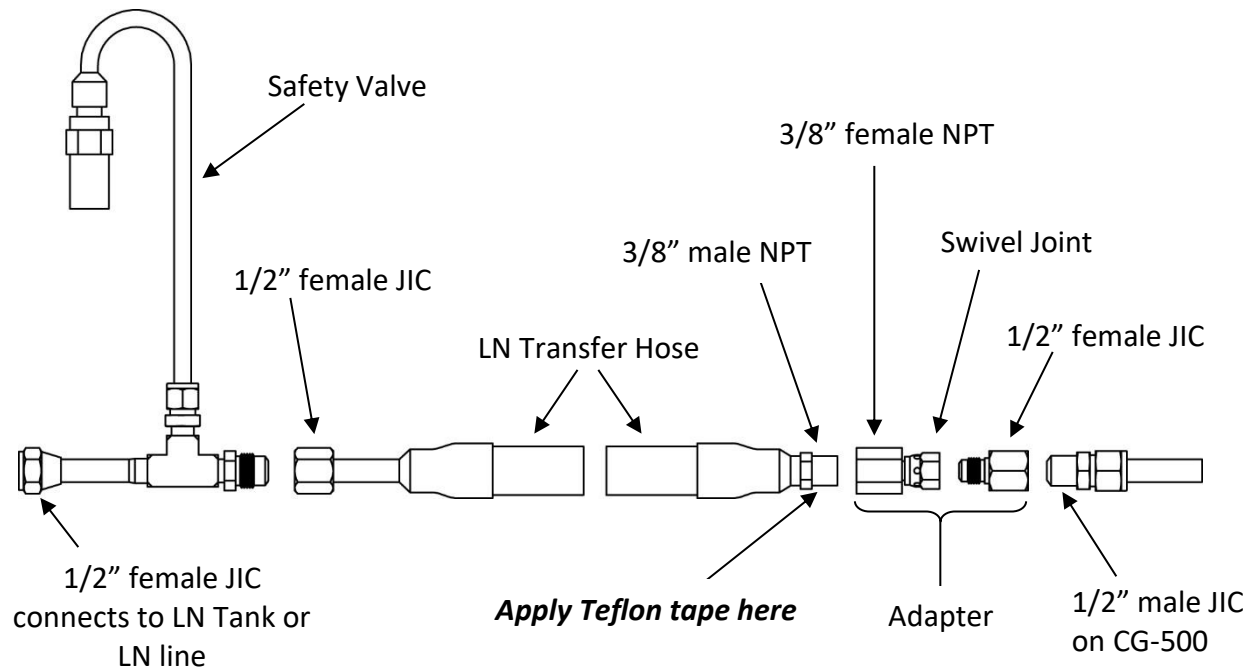

Figure 4 - Liquid Nitrogen Connection (included with CG-500, except for LN Transfer Hose)

4.4 Lid, Coil Assembly and Gate, LN Sensor

The lid of the CG-500 Freezer/Mill supports the coils (dual electromagnet assembly), two precooling chambers, and grinding Chamber 1 and Chamber 2 enclosure. To open the lid, hold the lid down with one hand, and with the other hand pull the upper end of the latch toward you. Then pull the lower end of the latch to detach it from the cabinet. Release the lid and it will raise up by the gas spring arms. The gas spring arms will keep the lid in the upright position. The lid must be open for insertion and removal of vials.

A vial can be inserted into either precooling chambers, or Chamber 1 and Chamber 2 of the assembly. The Gate keeps the vial(s) in place during grinding for Chambers 1 and 2 only. The vials in the precooling chambers will remain secure and unaffected by the magnetic coils in Chamber 1 or Chamber 2. **Do not run the CG-500 Freezer/Mill without a loaded sample vial in the grinding Chamber(s) that is active (programmed to grind).**

The Gate (Figure 1) holds the vial(s) in Chambers 1 and 2 during grinding. To lock a vial in place, turn Gate Handle to the left, and position it to pass through the slot in the open Gate. Now close Gate and turn Gate Handle to the right against the Gate, then fold down Gate Handle to

4.4 Lid, Coil Assembly and Gate, LN Sensor (Cont'd)

lock the Gate during grinding. Always use the proper adapters for mid-size, small vials and microvials (Section 4.5).

The lid must be completely closed and latched for the CG-500 Freezer/Mill to operate. Push the lid down and hold it down while engaging the bottom part of the latch, and then lock the latch by pushing its top end toward the cabinet.

The liquid nitrogen (LN) sensor is located behind a shield on the back wall of the LN tub. While in Auto Fill mode, with the CG-500 Freezer/Mill connected to the LN Tank, the unit will add liquid nitrogen automatically to maintain the proper LN level. If the unit is started and the LN Level is low, the screen will display status as LOW LN LEVEL. If the LN runs low during a grinding program the same message will appear "LOW LN LEVEL" and the program will stop. Close the lid, "TOUCH RESUME BUTTON", and the grinding program will begin where it left off.

NOTE: To keep a Run from being interrupted by low liquid nitrogen levels, use the Auto Fill mode with LN Tank connected. In the optional Manual Fill mode the unit will not run if the proper LN level is not maintained. The liquid nitrogen should be topped off when needed. The Freezer/Mill warranty does not cover damage to the magnetic coils caused by operating the mill with little or no liquid nitrogen.

4.5 Grinding Vial Sizes, Adapters, and Vial Openers

Large vials (6801, 6871, 6803) are run one per chamber in the CG-500 Freezer/Mill, without any adapter. Large vials can be opened using the 6804 Extractor/Vial Opener, which is part of the 6870L Accessory Package. (Or the optional 6808 Extractor/Vial Opener, available for purchase)

Mid-Size vials are run one per chamber, but the 6887 Mid-Size Adapter must be used with the 6881 and 6883 vials, and the 6888 Adapter must be used with the 6885 vial. The 6887 Adapter included in the 6870M Accessory Package (6888 Adapter is sold separately). Mid-Size vials can be opened by the 6804 Extractor/Vial Opener, but only by first installing the 6884 Mid-Size Vial Adapter. (The 6808 Extractor/Vial Opener with 6808M Mid-Size Vial Adapter Kit, is available for purchase)

Small vials (6751, 6761, 6771, 6781S) can be run one, two, three, or four per chamber in the CG-500 Freezer/Mill. However, the small vials must be used in conjunction with the 6807 Vial Holder insert for the grinding chamber. The vial holder keeps the vials parallel to each other and parallel with the chamber, so each impactor moves back and forth in line with the magnetic field during grinding.

4.5 Grinding Vial Sizes, Adapters, and Vial Openers (Cont'd)

The vial holder is needed to create a good tight fit against the Gate, and to hold the vials in the correct orientation during grinding.

Microvial 6757 set can be run one to four at a time with the 6807 Vial Holder. Each 6757 set includes three 6757V Microvials. Microvials can be opened using the 6758 Extractor.

5.0 TOUCHSCREEN DISPLAY

The CG-500 Freezer/Mill is programmed and operated through a series of touchscreen displays. Transitioning between screens, and all programming and operating commands, are done by touching the screen with a fingertip or stylus. **Do not use a sharp point as this can damage or deface the screen.**

5.1 Logo Screen

When the power is switched ON at the back of the mill, “FreezerMill” appears during start-up as the software loads. Then the screen will switch to the **Home Screen**, as shown in Figure 5. From the Home Screen the Control Panel, Saved Protocols, Run History, and Settings can be accessed by touching the buttons displayed.

The Home Screen icon can be found on the following screens (e.g. Control Panel, Saved Protocols, Run History, and Settings) positioned to the bottom right of screen. Touching the Home Icon allows the users to return to Home Screen.

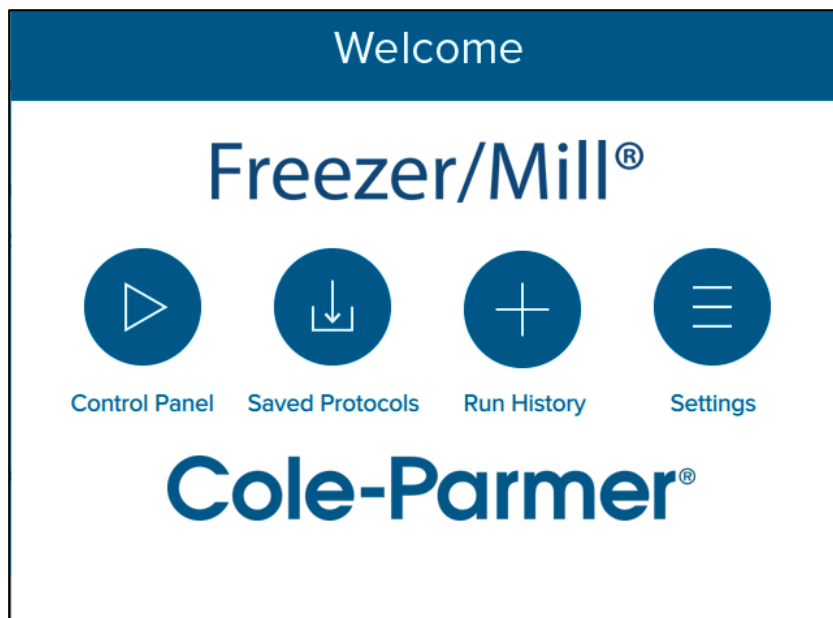

Figure 5 - Home Screen

5.2 Control Panel

The Control Panel displays the programmed run parameters, as shown in Figure 6. Changes to the run settings, and to activate Mono or Dual grinding modes are made from this screen. In Mono mode the programmed run parameters will **Only** operate Chamber 1. If Dual mode is selected the run parameters (Figure 6), will operate Chamber 1 and Chamber 2 simultaneously.

To recall stored run protocols, touch the store/recall button located at the bottom right of the screen. (See section 5.4 for more information on Saved Protocols)

To return to the Home Screen touch the Home Icon.

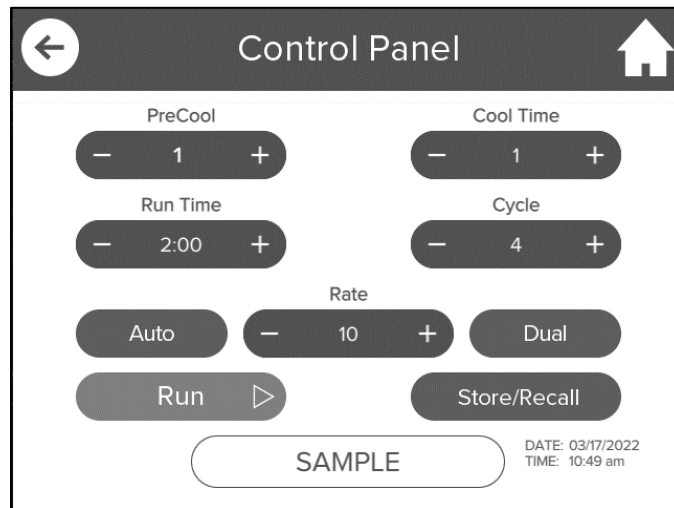

Figure 6 – Control Panel

The following sequence of events will occur from the current settings in Figure 6: Both Grinding Chambers, 1 and 2 will run, as indicated by the DUAL button color (blue).

1. Precool - the coil is inactive while the vial cools in liquid nitrogen for 1 minute. Samples must be precooled before grinding (10 minutes is recommended).
2. Cycle 1 - the coil is activated and the impactor grinds for 2 minutes at a rate of 10 cycles per second (20 impacts per second).
3. Cool Time - the coil is inactive for 1 minute between grinding cycles allowing coil and sample vial to cool down.
4. Cycle 2 - the coil is activated and the sample is ground for another 2 minutes.
5. Cool Time - the coil is inactive for 1 minute, as in step 3.
6. Cycle 3 - the coil is activated and the sample is ground for another 2 minutes.
7. Cool Time - the coil is inactive for 1 minute, as in step 5.
8. Cycle 4 – the coil is activated for the final 2 minute cycle. At the end of the final cycle the program is complete and the sample has been ground for a total of 8 minutes.

5.2 CONTROL PANEL (Cont'd)

In the **CONTROL PANEL**, Mono or Dual sample mode can be selected as well as to Auto Fill or to Manual Fill the CG-500 Freezer/Mill with liquid nitrogen. The STATUS BAR (top of screen) counts down the time remaining for a run.

To change the settings of a selected field, press the minus (-) or plus (+) buttons on the **CONTROL PANEL** screen. The minus (-) button decreases the number displayed and the plus (+) button increases the number displayed.

5.2.1 Starting a Programmed Run

When the Mono mode is selected the button is displayed as a blue button indicating Mono or the first grinding chamber is active. To change from Mono mode to Dual mode, touch the Mono mode button and the button will turn to Dual mode (both grinding chambers is active). Only the Button Mono or Dual will execute the programmed settings (Figure 6), when run button is touched. The Freezer/Mill can be started, stopped, or paused in the middle of a grinding program from the button selections to the right of the Run Screen.

The Auto Fill or Manual Fill buttons are also displayed on Control Panel. When a button is selected the button displayed as blue, indicating it is active. In Figure 6, Auto-Fill or Manual Fill mode has not been selected (note the buttons are gray). The CG-500 Freezer/Mill must be connected to a LN Tank or LN Line to run in Auto Fill mode. To change from Auto Fill mode to Manual Fill mode, touch the Manual button, the button will change from gray to blue indicating the unit will now be filled manually. The Auto-Fill will turn gray indicating it is inactive or no longer in Auto-Fill mode.

Open the lid and place the loaded sample vials in Chamber 1 and Chamber 2 (Dual mode), then lock the Chamber Gate Handle (Section 6.3). Additional loaded sample vials can be placed in the precool chambers while running samples in Chambers 1 and 2 (Figure 1). By precooling the additional loaded sample vials, the PRECOOL time for these samples can be decreased or eliminated during the next run. After all vials have been loaded, lower the lid and secure the latch. The Auto Fill LN System will fill the tub with liquid nitrogen to the correct operating level. LN Filling will be displayed on screen as the LN fills the tub, as shown in Figure 7.

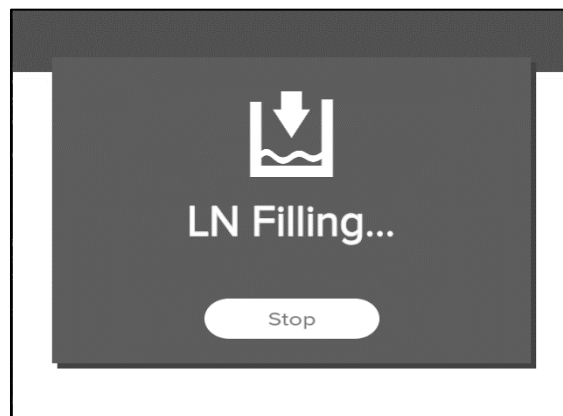

Figure 7 – LN Filling screen

5.2 CONTROL PANEL (Cont'd)

If the LN Tank is empty and unable to fill the tub with liquid nitrogen change the LN Tank and touch RESUME to begin operation.

If the lid is not completely closed and latched, the screen will display LID OPEN, as shown in Figure 8. To abort the program touch the stop button. To continue with the program touch the RESUME button after the lid has been completely closed. When the tub is filled with liquid nitrogen to the correct level, and the lid is securely latched, the STATUS BAR will turn **green** and begin counting down. The PRECOOL sequence will start indicating the beginning of the grinding program.

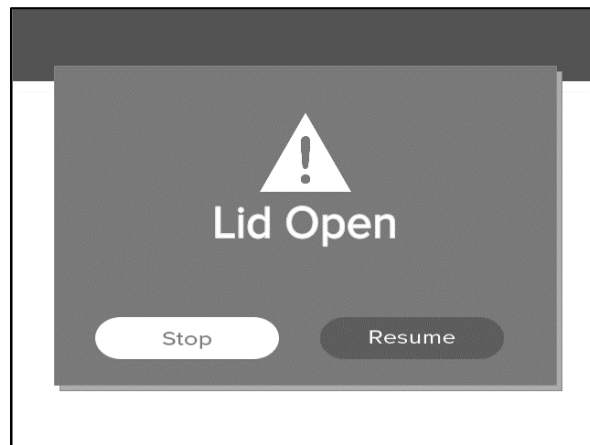

Figure 8 – Lid Open screen

During the PRECOOL stage the TIME REMAINING line counts down the time for that stage in 1-second increments for Mono or Dual mode. To pause the program touch the pause button. To continue the program, touch the RESUME button. To abort the program, touch the stop button. To start a new program, touch the run button.

When the programmed stage (e.g. PRECOOL) is complete a **green check mark** will appear next to that field. (Samples must be precooled)

5.2 CONTROL PANEL (Cont'd)

Following the PRECOOL stage is the first GRINDING cycle stage. The RUN TIME line will display the time remaining in that cycle of the grinding stage. At the end of each grinding period a **green check mark** is placed next to that field. If there are 4 total grinding periods, the CYCLES line will countdown to “0”.



Figure 9 – Run screen during grinding

As shown in Figure 9, the RUN TIME line indicates the 2 minute grinding period will begin after the Pre-Cool (1-min) is complete. Between any two grinding periods is the COOL DOWN stage. The COOL TIME line display, the time remaining in the COOL DOWN stage. The Cool Time for 1 minute is set to start as indicating by the yellow symbol. At the end of each Cool Time period a **green check mark** is placed next to that field. The Rate is 10 cps (cycles per second).

The STATUS BAR (top of screen) counts down the Time Remaining for the programmed run. The bottom of the screen displays the Protocol Name for the run. If no Protocol Name is assigned to the run as a Saved Protocol (Section 5.4) then the default name will be displayed as COUNTDOWN. When the grinding program has ended, the screen will display RUN COMPLETE (Figure 10). Touch the screen to return to the Control Panel.

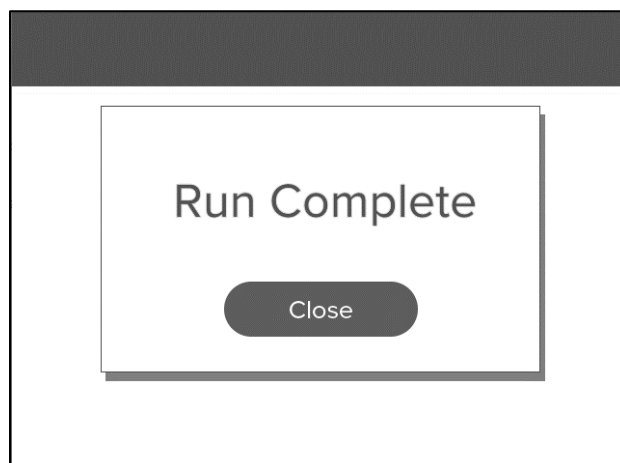

Figure 10 – Run Complete screen

5.2.2 Adjusting the Grinding Rate

While in the **CONTROL PANEL** screen, the only parameter that can be modified during grinding is the RATE. It is adjusted by touching the minus (-) and plus (+) buttons next to the Rate field. Touching the minus (-) button decreases the rate by 1 cps at a time, while touching the plus (+) button increases the rate by 1 cps. Tap or hold the minus (-) or plus (+) buttons until the desired rate is reached.

Rate is the number of back-and-forth cycles per second (cps) completed by the impactor. During one cycle the impactor strikes both end plugs of the vial, therefore a rate of 10 cps is equivalent to 20 impacts per second. The factory default setting for the rate is 10 cps. The maximum grinding rate is 15 cps and the minimum is 5 cps.

5.2.3 Stopping or Pausing a Run

To stop a program, touch the stop button on the **CONTROL PANEL** screen and the program will end. If the run button is touched after the program has stopped then the entire program will start over.

To pause during a grinding program, touch the pause button. The **RUN** will hold the settings at that moment (elapsed time, cycle, etc.). To resume the program, touch the Resume button. This will restart the program at the point at which it was paused. Alternatively, pressing STOP will end the program.

5.3 Changing Settings

To change parameters (precool time, grinding time, cool down time, cycles and rate), touch the minus (-) and plus (+) buttons on the **CONTROL PANEL** screen. The changes will appear in the area between the minus (-) or plus (+) buttons, as shown in Figure 11.

The CONTROL PANEL allows the user to change the parameters by touching the minus (-) and plus (+) buttons next to the field. Touching the minus (-) button decreases the parameter, while touching the plus (+) button increases the parameter. Tap or hold the (-) or (+) buttons until the desired number is reached. To run a program with the new settings, touch the run button.

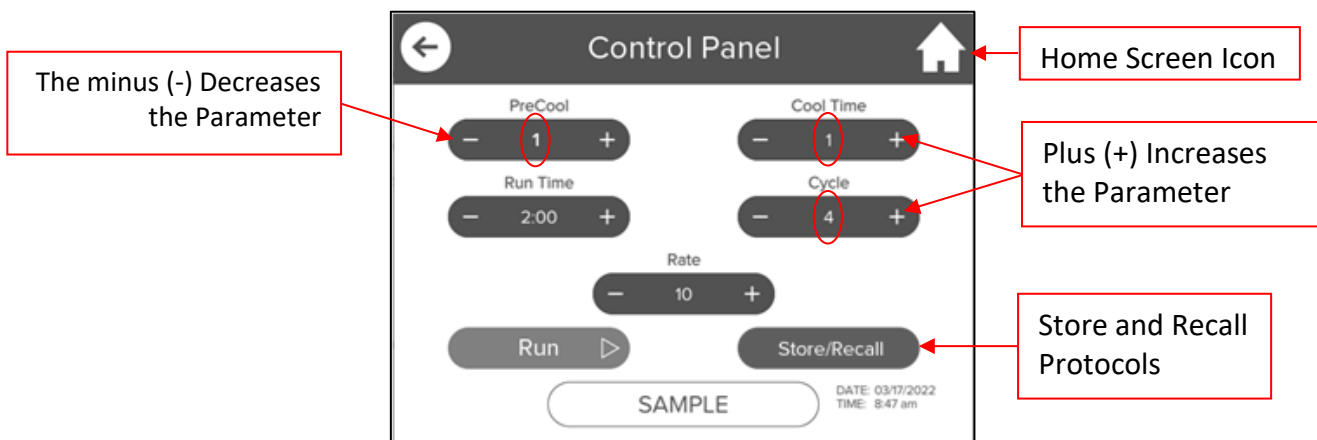

Figure 11 – Changing Settings

5.4 Saved Protocols

The **SAVED PROTOCOLS** screen is shown in Figure 12. In this example, three saved protocols have been stored and named (e.g. Hair, Bone, Soft Tissue). Up to 20 Protocols can be stored. access or make visible additional protocols, or vacant protocol spaces (e.g. User Protocol) swipe up or down the touchscreen. This brings up vacant protocol slots on the **SAVED PROTOCOLS** screen.

A saved program retains the settings for number of cycles, precool time, run time, and cool time between cycles. Be sure to adjust the rate to the desired setting after recalling a stored program.

The Default protocol recalls the last programmed run setting that was not saved. The Default protocol can be changed without saving the new settings, as described in section 5.4.

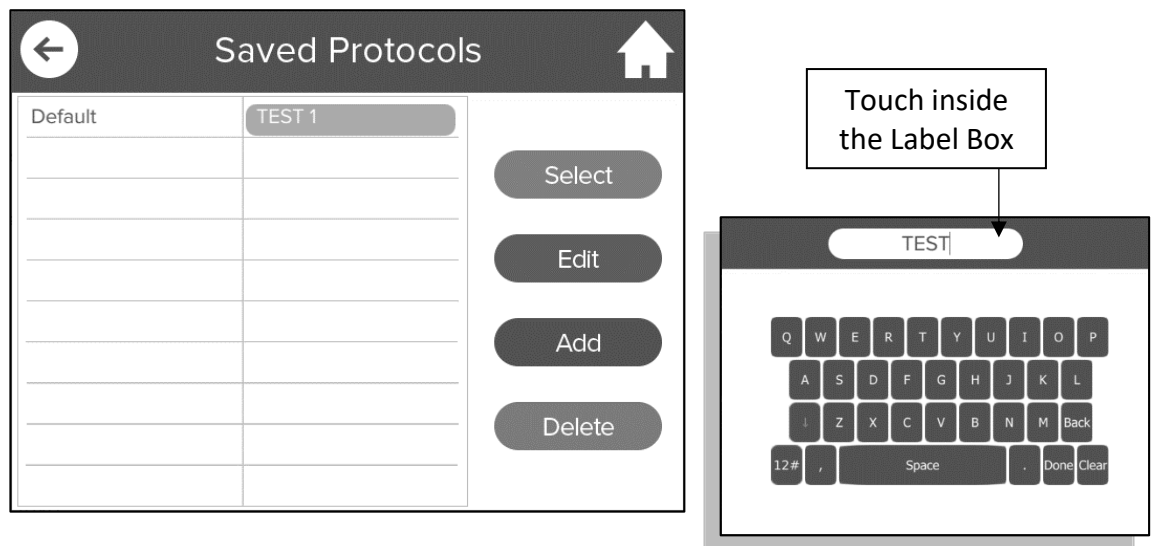

Figure 12 – Saved Protocols

5.4.1 Storing a new program

To store the new program or to recall a stored program, touch the store/recall button on the Control Panel screen (Figure 11). In the **SAVED PROTOCOLS** screen touch inside the Label Box, as shown in Figure 12.

This will bring up the **KEYBOARD** screen, a simplified version of the standard keyboard for a computer. In addition to number and letter keys, this keyboard has standard symbol keys (#, %) and four function keys (SPACE, BACK, DONE, and CLEAR).

As the letters/numbers are touched, they appear above the keyboard in the Label Box with a centered cursor. To access the number and symbol keys touch the 12# button located bottom left on the **KEYBOARD** screen. To switch back to letter keys touch the ABC button (same button) bottom left on the **KEYBOARD** screen.

5.4 Saved Protocols (Cont'd)

The Up/Down yellow arrow key on **KEYBOARD** allows the user to shift back and forth from upper case to lower case (the default is upper case). Touch Down arrow to switch to lower case. Or touch Up arrow to revert to upper case.

Touching the SPACE key advances the cursor one space. Touching the BACK key deletes one space. The CLEAR key deletes whatever has been entered in the Label Box.

Touch DONE button to save the name shown in Label Box. The label will appear as the name of the program in the **SAVED PROTOCOLS** screen (Figure 12).

The CANCEL key does not change anything on the screen, but returns the display to the **SAVED PROTOCOLS** screen.

To run the newly saved protocol, touch the protocol to highlight the name. Then touch the Select button to send protocol to the **CONTROL PANEL** screen. Review the parameters and touch the run button to initiate the protocol.

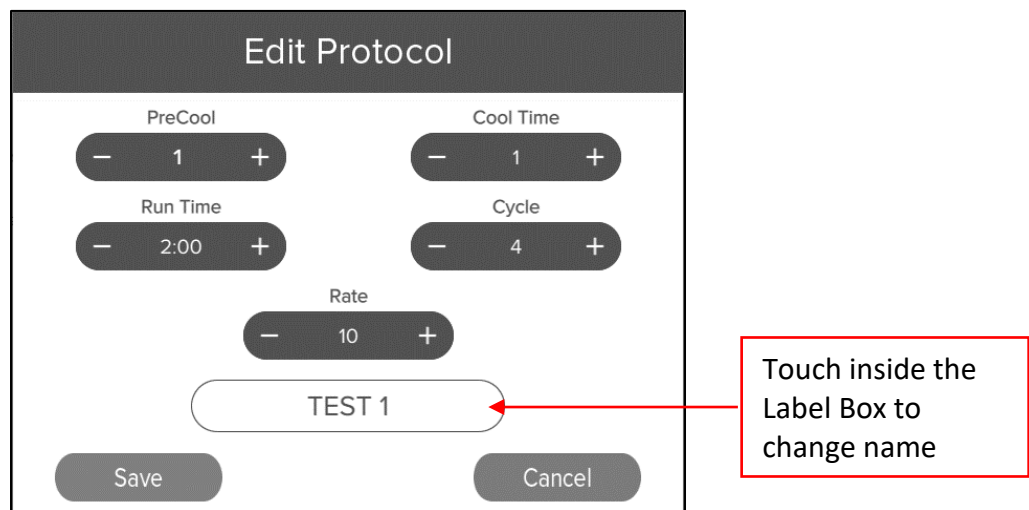

Figure 13 – Edit Protocol

5.4.2 Delete Protocol

To delete a saved protocol, touch the protocol to highlight the name. Then touch the Delete button. A pop-up window opens confirming to delete this protocol. Touch YES to clear or touch NO to keep the saved protocol.

5.4 Saved Protocols (Cont'd)



Figure 14 – Delete Protocol

5.4.3 Edit Saved Protocols

To edit a saved protocol, touch the protocol to highlight the name. Then touch the EDIT button. From the Edit Protocol screen change parameters and/or name, then touch the DONE button.

5.4.4 Recalling a program

In the **SAVED PROTOCOLS** screen, touch the protocol to highlight the name. Then touch the Select button to send protocol to the **CONTROL PANEL** screen. Review the parameters. To RUN the protocol touch the run button to initiate the protocol.

6.0 OPERATION

CAUTION: Be sure that the vent on the back of the CG-500 Freezer/Mill (Figure 2) is not blocked in any way. During operation, liquid nitrogen vaporizes in the Freezer/Mill and pressure is relieved through this vent.

6.1 Standard Auto Fill

When the CG-500 Freezer/Mill is set up for the first run of the day, with a loaded vial(s) in the grinding Chamber(s), make sure the unit is connected to a LN Tank or LN line and the LN valve is open. Choose Mono or Dual sample mode and Auto Fill, then go to the **CONTROL PANEL** screen and touch the run button. The Auto Fill valve will open and let liquid nitrogen into the tub. It is normal for the valve to close and open several times before the tub is full and the Precool timing starts. Liquid nitrogen boils and splashes as it enters the tub and this splashing may temporarily interfere with the upper LN sensor. The Auto Fill System has a built-in pause for the liquid nitrogen to stabilize before measuring the LN level again. The Precool countdown will not begin until the tub is full of liquid nitrogen to the proper operating level.

6.1 Standard Auto Fill (Cont'd)

During a long run, if the lower LN sensor detects a low liquid nitrogen level, the LN valve will only open during a re-cooling period. Note, the valve may open and close several times while the tub is filling however the timer will continue to countdown for the cooling period while the tub is filling. At the end of a run the liquid nitrogen level in the tub may seem low, but this is only because the lower LN sensor has not triggered the Auto Fill System to fill the tub with liquid nitrogen. The CG-500 Freezer/Mill Auto Fill System has been designed to work with typical grinding programs that involve a precooling period and repeated short grinding and re-cooling periods.

If you want to use the Freezer/Mill in a different way – for example, by having a single long period of continuous grinding – please call us first to make sure your plans and the Freezer/Mill are compatible. The lower LN sensor may not trigger the Auto Fill System to add liquid nitrogen during a single long period of continuous grinding.

6.2 Manually Adding Liquid Nitrogen

CAUTION: When working with liquid nitrogen directly or indirectly, cryogenic gloves must be worn to protect hands. Safety goggles should be worn at all times to protect eyes from accidental splashes or liquid nitrogen vapor.

Liquid nitrogen (LN) should only be added to CG-500 Freezer/Mill with the lid open. To open the lid, hold the lid down with one hand, and with the other hand pull the upper end of the latch toward you. Then pull the lower end of the latch to detach it from the cabinet. Release the lid and it will raise up by the gas spring arms. The gas spring arms will keep the lid in the upright position.

If the liquid nitrogen is above this level when the lid is closed, LN can splash outside the tub and drain excess LN out the vent in the rear of the Freezer/Mill. **Always close the lid slowly to avoid splashing.**

Liquid nitrogen is generally available either in a large tank with a flexible steel hose, or in a small Dewar. The CG-500 Freezer/Mill typically consumes 15-19 liters of LN during initial cool-down, and another 4-6 liters per hour, depending on use.

Insert loaded sample vials in the chambers and lower the lid to chill unit. Initially, liquid nitrogen will boil off vigorously, but as the tub cools the boiling will subside. When boiling has subsided, slowly lower the lid and secure the latch. Allow unit to remain closed for 1 to 2 minutes, then open the lid.

6.2 Manually Adding Liquid Nitrogen (Cont'd)

Once more, slowly lower the lid and secure the latch. **Caution: When the lid is closed and latched, nitrogen vapor which vents from the Freezer/Mill can displace the oxygen in a closed room and cause asphyxiation.** If the tub is overfilled, liquid nitrogen will also exit from the vent in the rear of the Freezer/Mill. A grinding program can now be run sample as outlined in Section 5.2.

CAUTION: Never overly force an end plug (warm or cold) into a polycarbonate cylinder (warm or cold). Polycarbonate shrinks when chilled, and can crack if stressed. If the cylinder has cooled to the point that the end plug fit is too tight, allow the cylinder to warm up before inserting the end plug.

6.2.1 Introduction and General Recommendations

As a rule of thumb, the sample pieces should be small enough to freely move inside the vial as the impactor moves back and forth during grinding process. If sample is an irregular shape, it may be necessary to cut sample pieces to smaller size. Place impactor in vial and fill the vial 1/3 to 1/2 the volume with sample pieces. Typical sample sizes for the various size of vials are shown below in Table 1.

Table 1. Typical Sample Sizes

Sample	Large Vial 6801, 6803	Mid-Size Vial 6881, 6883, 6885	Small Vial 6751, 6761, 6771, 6781S	Microvial 6757
Plant tissue, bone, muscle, etc.	20-50 g	5-20 g	2-5 g	100-300 mg
Polymer pellet	10-20 g	2-10 g	1-2 g	NA

Virtually, no two materials will grind the same. Therefore, it is important to design the grinding process to attain the desired particle size or smallest possible particle size for any material. Key parameters in the design include precool time, grinding time, cycles, impactor rate as well as sample weight and sample size. Through grinding trials and guidelines as described in this Manual a custom procedure can be developed based on sample composition. Avoid overfilling the vial as this greatly reduces grinding efficiency.

If at first the sample doesn't grind as intended, try these strategies:

- Reduce the overall weight of the sample. (Some fibers and thin films may grind best in the Small vial with a sample weight of 1-2 g.)
- Reduce the size of the individual pieces to 1/4 or 1/8 inch (6 to 3 mm).
- Increase the Precool Time. (15 minutes of precooling is about the maximum necessary for most samples to reach LN temperatures)

6.2 Manually Adding Liquid Nitrogen (Cont'd)

- Grind longer. (In Manual Fill mode, 20 minutes of actual grinding time is the maximum recommended for one run, due to the liquid nitrogen capacity of the tub, but you can top off the LN and repeat the run if needed.)

6.2.2 Size of Sample Pieces

The size of sample pieces is important. For uniform results in Small Vials, most samples should be cut into pieces smaller than 1/4 inch (6 mm). Very tough samples such as fresh bone should be cut smaller, down to 1/8 inch (3 mm). Samples can be cut proportionately larger for Mid-Size and Large Vials. In any case, the size of the pieces should be controlled, and consistent from sample to sample. There are several reasons for this:

- The more irregular the size of the sample pieces, the more difficult it is to predict the results. Similar sized sample pieces produce a more uniformed grind.
- Thin fibers and films in particular can be very difficult to cryo-grind unless they are cut into small pieces first. Wads of long fibers and crumpled balls of film take up extra room and can be elastic, even at cryogenic temperatures.
- Tough samples in large pieces can be very difficult to grind, and in rare cases may damage the vial. A large, wedge-shaped piece of bone or a tough polymer can act as a wedge to push a moving impactor through the side of the polycarbonate tube.

6.2.3 Loading a Sample into a Vial at Room Temperature

Attach the end plug to one end of a center cylinder and insert impactor. Now load sample and attached the other end plug to close vial. Shake the vial to make sure the impactor has room to move back and forth.

6.2.4 Loading a Precooled Sample into a Vial and Keeping it Cold

Some samples must be kept cold prior to grinding, such as plant or animal tissue being prepared for RNA extraction. When a sample is precooled and must be kept cold throughout the grinding process, the loading procedure is more elaborate.

Attach the end plug to one end of a center cylinder. Then place the cylinder, end plug side down in a shallow liquid nitrogen bath. The liquid nitrogen level should completely cover the end plug and 1 inch up the side the center cylinder. The vial racks with the 6870L and 6870S Accessory Packs can be placed in an insulated container to hold the vials upright during LN chilling. At the same time, chill the impactor separately. As soon as the submerged end of the vial is chilled add in the precooled sample and then the chilled impactor. Now carefully insert the other end plug (which is at room temperature) into the open end of the cylinder. Do not let the precooled sample touch the “room temperature” end plug. The vial can now be carefully placed in the precooling chamber or the grinding Chamber.

6.2.5 Loading a Very Small Sample into a Vial and Keeping it Cold

A similar loading technique to Section 6.2.4 can be used to grind very small samples with an upright, open pre-chilled vial. Place the sample on the chilled end plug and add a small amount of fluid such as an extraction medium or water. The frozen fluid will bulk up the sample which will allow the sample to be more efficiently ground during the run cycle. To speed up this process with Small-sized vials like the 6751, some users first prepare small “ice cubes” of the sample frozen together with 0.5 ml to 1 ml of fluid.

6.3 Loading Vials into the Freezer/Mill

A vial can be inserted into either precooling chambers, Chamber 1 and Chamber 2 of the assembly. The Gate keeps the vials in place during grinding for Chamber 1 and 2 only. Vials in the precooling chamber will remain secure and unaffected by the magnetic coils in Chamber 1 or Chamber 2.

The Gate holds the vials in Chambers 1 and 2 during grinding. To lock a vial in place, turn Gate Handle to the left, and position it to pass through the slot in the open Gate. Now close Gate and turn Gate Handle to the right against the Gate, then fold down Gate Handle to lock the Gate during grinding. Always use the proper adapters for mid-size, small vials and microvials (Section 4.5).

The lid must be closed and latched for the Freezer/Mill to run. Push the lid down, hold it down while engaging the bottom part of the latch, and then lock the latch by pushing its top end toward the cabinet. The grinding program can be run using the controls described in Section 5.

6.4 Removing Vials from the Freezer/Mill

To remove samples, open the lid by holding the lid down with one hand, and with the other hand pull the upper end of the latch toward you. Then pull the lower end of the latch to detach it from the cabinet. Release the lid and it will raise up by the gas spring arms. The gas spring arms will keep the lid in the upright position. The lid must be open for removal of vials. To unlock a vials in grinding Chambers 1 and 2, lift Gate Handle and turn Gate Handle to the left, and position it to pass through the slot in the closed Gate. Open Gate and remove vials.

6.5 Opening, Emptying, and Cleaning Freezer/Mill Vials

6.5.1 Opening a Vial

To open a vial, slip the open end of the appropriate Extractor/Vial Opener over a threaded end plug, align the pegs in the end plug with the slots in the Extractor, and turn the knob clockwise until the end plug is drawn out. If the end plug is drawn out within a millimeter or two of the end of the center cylinder and stops, rock the Extractor gently to dislodge the end plug. Always be careful that the vial does not fall and spill its contents.

If the Extractor/Vial Opener jams with the end plug part way out, let the vial warm up before removing the end plug. Forcing out the end plug can damage the Extractor or break the

6.5 Opening, Emptying, and Cleaning Freezer/Mill Vials (Cont'd)

polycarbonate center section. The best way to prevent the Extractor from jamming is to make sure both the Extractor and the threaded end plugs are dry and clean before you use them.

If the Extractor/Vial Opener jams when being threaded into a cold end plug, it is probably due to water condensing and freezing on the extractor screw. The water freezes when it contacts a cold end plug. Wipe off the screw with a paper towel before each use. Note that the end of the screw is tooled with an "X" cut to help remove any ice that forms on the end plug. Chilled vials can also be opened easily and quickly with the optional accessory 6808 Extractor for Large Freezer/Mill Vials.

On rare occasions an end plug will stick in the vial when cold, even if the Extractor screw and end plug threads are dry and clean. If this happens do not force the end plug out, as the vial and/or the Extractor may become damaged. Allow the vial to warm up. The end plug can be extracted easier by allowing the vial to warm up gradually, or by wrapping vial in several layers of cloth or paper towels.

CAUTION: Pressure can develop inside a Freezer/Mill vial as it is warming. As pressure builds, an end plug can pop out with force and the sample can be lost. For this reason handle vials with care. It is best to open chilled vials immediately after removing them from the Freezer/Mill.

6.5.2 Emptying a Vial

As soon as an end plug is removed from a cold vial, empty the contents of the vial into a suitable container, the quicker the better as condensation on a cold sample occurs rapidly. Often it is helpful to tap the closed end of the vial to release the ground sample. Remember that the impactor may slide out ahead of the contents or with them, and that the longer the sample is exposed to air, the more moisture it will acquire. Note, samples which were tacky, spongy, etc., at room temperature will return to that state as they warm up, and may agglomerate.

The impactor will have to be separated from the sample and can be handled with gloved fingers, a strong magnet, or tongs. Tools without a good gripping surface are likely to slip off the impactor. The 6870L and 6870S Accessory Packs include a Magnetic Extractor (6791). This is a rod with a magnetic tip that can be used to remove the impactor from a vial before emptying the contents.

If some condensation on a cold sample is unacceptable, either wait for the sample vial to warm up before opening and emptying it, or open and empty a chilled vial in a glove box filled with dry nitrogen gas.

Small amounts of sample usually adhere to the vial's impactor, end plugs, and plastic cylinder. Brushing or scraping these surfaces of the vial can often recover this fraction of the sample. Again, speed is important to minimize condensation and other effects of warming.

6.5 Opening, Emptying, and Cleaning Freezer/Mill Vials (Cont'd)

If it is necessary to recover 100% of the sample, let the vial warm up and add some water or other liquid that will not affect the polycarbonate (Section 6.5.3). Shake the vial, empty it onto filter paper, and rinse again if necessary to recover the entire sample.

6.5.3 Cleaning the Vials

Freezer/Mill vials may be cleaned quickly and easily by placing them under warm running water. If the vial is cold a coating of ice will form on the steel parts, but will melt quickly as the vial is kept under warm running water.

The plastic center cylinders for all vials, and the Poly-Vial end plugs and encapsulated impactor, are all made of polycarbonate. **While this polymer is very tough at low temperatures, it is sensitive to alcohol, acetone, and other organic solvents, and should be cleaned only with soap and water.** A mild bleach solution will control organic contamination. Polycarbonate can be autoclaved, but this will weaken it.

Before re-using polycarbonate parts, **always** inspect them for cracks or other damage. They may last through dozens of samples uses, but as soon as they begin to crack they should be discarded. Liquid nitrogen can enter through cracks and vaporize when vial is removed from Freezer/Mill. As the vial warms vaporized LN will build pressure and an end plug can pop out with force so the sample may be lost.

If sample adheres to the steel end plugs and impactor, they can be cleaned with water and soap or detergent, or with organic solvents. If they must be disinfected or cleaned of any organic residue, they can be washed with mild bleach solution or chemical cleaners or autoclaved, but should always be dried immediately after use. The steel parts in the 6751, 6801, and 6881 vials are made from 440C Stainless Steel, a magnetic stainless steel, which is corrosion-resistant but may to some extent rust if left in contact with water for too long. All stainless steel parts should be dried after washing.

The steel parts of the chromium-free 6771, 6871, and 6883 vials can also be cleaned with water and soap, or autoclaved. **Do not wash with bleach or chemical cleaners.** Chromium-free steel is not rust-resistant and must always be dried immediately after washing. Store Cr-Free Vial parts in a sealed bag with a desiccant.

Rust on steel Freezer/Mill parts can be removed by scrubbing them with steel wool or an abrasive cleanser. If rusting persists, store the parts in a sealed bag with a desiccant.

6.6 Checking the Liquid Nitrogen Level

In Manual Fill mode only, every time a vial is inserted into or removed from the Freezer/Mill, note the level of liquid nitrogen in the tub. If the LN level is Low the mill will not run. Add LN as needed. A cumulative grinding time of more than thirty minutes per run is not recommended, after that much grinding the liquid nitrogen level may become low to the point where the LN sensor will shut down the mill. If the LN sensor stops the grinding program, the mill can be refilled with liquid nitrogen and the grinding program resumed where it stopped.

7.0 Run History

To recall the Run History touch the Run History button. The Date, Time, and Run Protocol data are stored on this screen, as shown in Figure 15. The run information can be exported to other computer devices via the USB Port located on the back of the Controller. To export run data touch the Export History button at the bottom right of the screen. To clear Run History or delete Run History permanently from data storage touch the Clear History button at the bottom left of the screen. To return to the previous screen touch the back arrow button at the top left corn of the screen.



Note, the Export History button will have a dimmed or muted green appearance which indicates it is inactive. After a flash drive or USB cable (connected to computer device) is inserted into the port the button will turn a brighter green indicating it is active.

Figure 15 – Run History screen

8.0 System Settings

To access the Settings Screen touch the Settings Icon on the Home Screen (Figure 4). The System can be upgraded, Diagnostics view/exported, and files exported (Run History, Saved Protocols) and saved protocols imported, as well as the time display changed from 12-hour to 24-hour, and Time and Date can be entered or changed, as shown in Figure 16. Touch inside window to change the Date or Time. A pop-up window opens to enter Time or Date. Touch the SET button to confirm the change. Select 12 or 24 hr. time, which will be displayed on the Run screen. Touching the back arrow button returns the user to the previous screen.

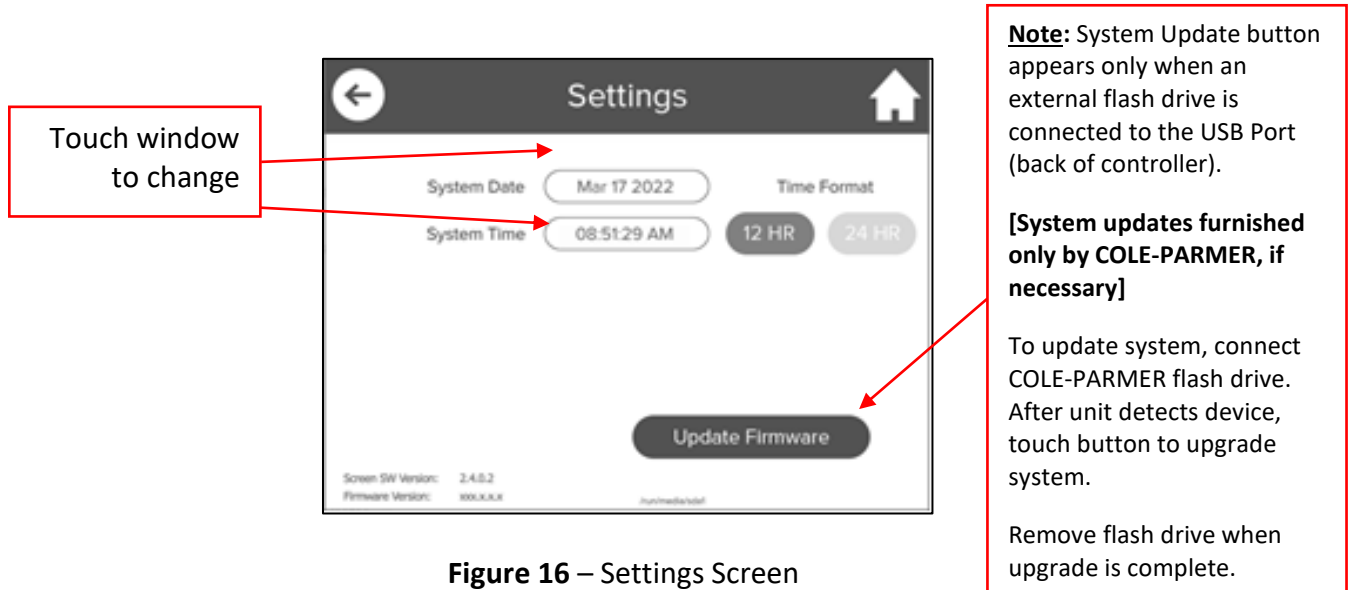

Figure 16 – Settings Screen

9.0 MAINTENANCE

The CG-500 Freezer/Mill has been designed to provide trouble-free operation over a long period of time. To assure proper performance it is very important to keep the unit clean. When the Freezer/Mill is at room temperature, any spilled powders or liquids should be wiped up immediately. The internal tub should be wiped clean with a damp cotton cloth after every use.

This should prevent the buildup of any powders, mold/mildew, or other residue over the life of the unit. If any samples, powder materials, or liquids are spilled inside the unit during a sample run, wait until Freezer/Mill is finished for the day, the liquid nitrogen has evaporated, and the mill has warmed up to room temperature before attempting to clean it. Once the unit has attained room temperature, wipe down the unit as indicated previously. After every period of use, the mill will become wet with condensation due to the Freezer/Mill picking up moisture from air when it is cold.

To maintain the exterior of the unit, first disconnect the Freezer/Mill from its electrical source. Then lightly spray with a mild window cleaner or similar product and wipe unit down. If the CG-500 Freezer/Mill requires service, please call Cole-Parmer Customer Service for assistance.

10.0 TROUBLE-SHOOTING GUIDE

PROBLEM	POSSIBLE CAUSE	POSSIBLE SOLUTION
The unit does not turn on.	<p>No Power</p> <p>No Power</p> <p>Circuit Breaker tripped</p>	<p>Make sure power cord is plugged into outlet and inlet.</p> <p>Check outlet for power and correct as required.</p> <p>Turn unit OFF then ON.</p> <p>Call COLE-PARMER for service or repair.</p>
Screen displays "LID UP".	<p>Safety interlock switch not engaged.</p> <p>Lid is not closed completely.</p>	<p>Close the lid and latch,</p> <p>Push the lid closed and latch into place.</p>
Screen displays "LN LEVEL LOW".	Liquid nitrogen sensor detects inadequate liquid nitrogen level.	In Auto Fill mode, check LN Tank and replace if empty. Check hose assembly for LN leaks. In optional Manual Fill mode, pour more liquid nitrogen into the tub.
Coil gets very warm.	Low liquid nitrogen levels.	In Auto Fill mode, check LN Tank and replace if empty. Check hose assembly for LN leaks. In optional Manual Fill mode, pour more liquid nitrogen into the tub.

10.0 TROUBLE-SHOOTING GUIDE (Cont'd)

PROBLEM	POSSIBLE CAUSE	POSSIBLE SOLUTION
Impactor does not rapidly move back and forth in vial.	Water in vial has frozen the impactor.	Remove vial and replace vial and contents with a dry unit or tap ends of the vial on counter to free impactor.
	Impactor is magnetized.	Remove impactor, turn end-for-end, or demagnetize impactor and reinsert.
	Too much sample in the vial or sample pieces are too large.	Remove some sample from the vial and start again.
Flanged end plug doesn't come out the cold vial.	End plug/tube joint too tight when very cold.	Allow vial to warm up.
Blunt end plug doesn't come out room temperature vial.	Hard to grip.	Warm vial under warm water. Use wide-jaw pliers if necessary.
Extractor jams.	Water on extractor screws or bell.	Dry extractor before each use.
	Ice in threaded hole of end plug.	Dry end plugs thoroughly before using.
Plastic center cylinder cracks.	Cylinder cleaned with alcohol or other organic solvent.	Use bleach, detergent, and water to clean cylinders.
	Vial assembled when chilled.	Never force end plugs into cylinder.
	Sample piece acts as wedge.	Reduce size of sample pieces. Make sure there are no sample particles in mouth (opening) of cylinder.

11.0 WARRANTY

Cole-Parmer® guarantees its products against defects in materials or workmanship for three years from the date of original shipment. Repairs, replacements, or parts are guaranteed for 30 days or for the remaining original warranty period (whichever is greater) for the item that was repaired or replaced. Items not produced by Cole-Parmer carry the manufacturer’s warranty only. The Freezer/Mill wear parts include the dual magnetic coils.

Wear Parts	
Part No.	Description
40256	Solenoid Coil

The customer pays return freight for warranty claims. If the warranty claim is valid, Cole-Parmer will pay return freight to the customer. However, Cole-Parmer reserves the right to judge whether a malfunction during the warranty period is due to defects in materials, or workmanship, or to wear, negligence, or misuse.

11.1 Product Specifications

Every effort has been made to provide complete and accurate product operating information in this Manual. However, since specifications are subject to change without notice, changes may be made from time to time to improve the performance, reliability, and function of the product. Therefore, slight changes that are not reflected in the current illustrations should be considered minor and inconsequential for the purposes of this Operating Manual.

11.2 To Arrange a Return Shipment

We want you to be satisfied with your purchase from Cole-Parmer®. Please bring any problem to our attention, but please DO NOT RETURN any item before contacting us for a Return Authorization Number and instructions. Unauthorized returns will be refused. The cost for all return transportation is the responsibility of the customer. Credit for returned merchandise will be issued only after goods have been received and inspected. Returned goods are subject to a 25% restocking charge.

12.0 INSTRUMENT DISPOSAL

In accordance to the EU Directive 2012/19/EU covering Waste Electrical and Electronic Equipment, all equipment with the disposal symbol must not be disposed of with general waste. (See Figure 17)



Figure 17 – Disposal Symbol

Throughout the European Community, guidelines regarding disposal regulations may vary from territory to territory. Please contact the national legislation or local authority for more information on proper disposal of all equipment with this symbol.

13.0 CONTACT US

Repair Service

Phone: 1.732.623.0465

Cole-Parmer
65 Liberty St
Metuchen, NJ 08840
US

Attn: Service and Repair

Please include RA Number on the shipping label.

Cole-Parmer®

an Antylia scientific company

625 East Bunker Ct.
Vernon Hills, IL 60061
US

US

T: +1.800.323.4340 or
+1.800.323.4340

E: sales@antylia.com

W: coleparmer.com

Germany

T: +49 (0) 9377 92030

E: de.sales@antylia.com

W: coleparmer.de

Canada

T: +1.514.355.6100

E: info@antylia.ca

W: coleparmer.ca

India

T: +9122 61394444

E: info@coleparmer.in

W: coleparmer.in

China

T: 86.21.5109.9909

E: sales@antylia.com

W: coleparmer.cn

Italy

T: +39 (0)2 84349215

E: it.sales@antylia.com

W: coleparmer.it

France

T: +33 (0) 1486 37800

E: fr.sales@antylia.com

W: coleparmer.fr

UK

T: +44 (0) 1480 272279

E: uk.sales@antylia.com

W: coleparmer.co.uk

Other

T: +1.847.549.7600